



共创 共享 共发展

Creating Enjoying And Developing Together

PRECIOUS®  
sewing machine



中国·汇宝科技集团有限公司

CHINA · PRECIOUS SCIENCE AND TECHNOLOGY GROUP CORPORATION LIMITED

Http: // www.precious.com.cn

E-mail: precious@precious.com.cn

地址: 中国浙江台州市黄岩区黄椒路333号

电话: 86-576-84163333(总机)转

传真: 86-576-84161188 84161177

内贸部电话: 86-576-84161133 84161113

国贸部电话: 86-576-84161199 84163009

全国免费咨询电话: 8008576803

ADD: No.333.Huangjiao Road ,Huangyan District,  
Taizhou Zhejiang China.

TEL: 86-576-84163333 (board) switch

FAX: 86-576-84161188 84161177

Domestic Trade Department:

86-576-84161133 84161113

International Trade Department: 86-576-84161199 84163009

Free Consultation Phone number(within china): 8008576803

**PRECIOUS**<sup>®</sup>  
sewing machine



# 中国缝制机械 行业排头兵工业企业

**PRECIOUS<sup>®</sup>**  
sewing machine

**品质闪耀 惊世巨作**  
Shining quality Fantastic masterpiece

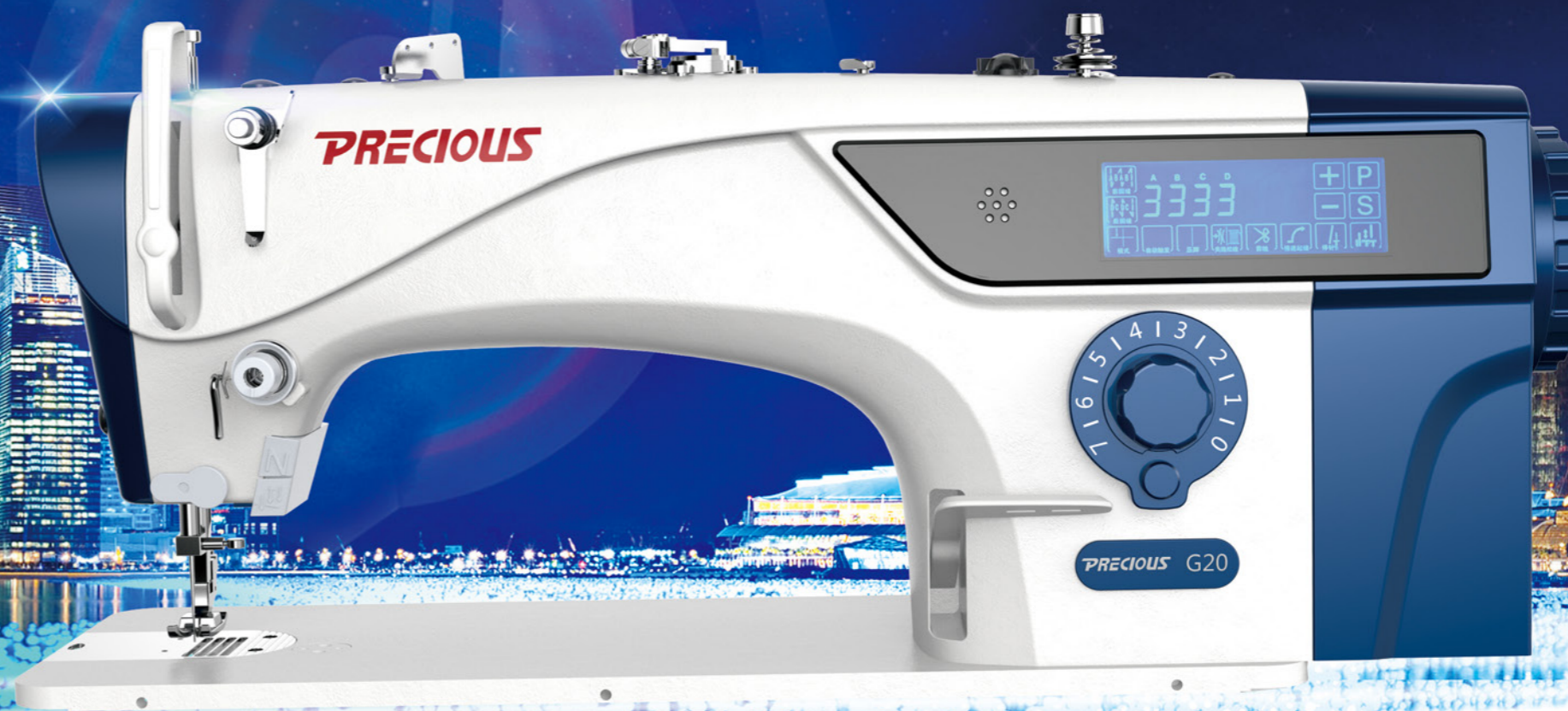



汇宝集团二区

## 企业简介 INTRODUCTION

汇宝科技集团有限公司是集科研、制造、贸易为一体的综合性现代化企业。产业涉及缝制设备制造、纸箱包装、第三方质检技术服务等。集团总占地面积105,000余平方米。

缝制设备制造为集团的主导产业。核心企业之一浙江汇宝缝纫机股份有限公司现已成为生产、销售缝纫机系列产品的专业性公司。公司占地面积50,000余平方米，拥有国际最先进的自动化生产线，采用精益化生产和信息化管理模式，形成了从产品研发、质量控制到整机和零部件制造、销售及售后服务等一整套完备体系。公司已通过ISO9001:2008质量体系认证、ISO14001:2004环境体系认证、欧盟CE认证、清洁生产认证等。“汇宝牌”工业缝纫机于2006年同时荣膺“浙江省著名商标”、“浙江省名牌产品”；2008年被评为“浙江省诚信企业”、农行浙江省分行“企业资信等级AAA级”单位；2009年1月“汇宝”商标荣获中国驰名商标；2010年被认定为国家级高新技术企业，荣获浙江省科技型企业。2011年被评为中国缝制机械行业排头兵工业企业，浙江省高新技术研发中心。2012年，被评为国家火炬计划产业化示范项目企业、浙江省守合同重信用AAA级企业，“汇宝”商号荣获浙江省知名商号。2013-2016年，连续四年被评为中国缝制机械行业十强企业，中国轻工业成长能力百强企业，安全生产标准化国家二级企业。

我们始终坚持以科技创新为发展动力，以国际化品牌为追求目标，坚持“先做精、后做强、再做大”的战略方针，秉承“共创、共享、共发展”的核心理念，切实做到国际国内市场并重，发达国家和发展中国家并举。希望通过我们的努力，为客户创造价值，提供增值服务，期待与您携手共创辉煌！



Precious Science and Technology Group Corporation Limited is a comprehensive and modern enterprise, which covers scientific researches, manufacturing and trade. Business involves sewing machinery equipment manufacture, carton package, third-party quality inspection technical service and so on. The area of the group is more than 105,000 square meters.

Sewing facilities manufacturing is the pillar industry in our group. As one of the core enterprises, Zhejiang Precious Sewing Machine Co., Ltd has become a specialized company in producing and selling products of sewing machine series. Zhejiang Precious Sewing Machine Co., Ltd is more than 50,000 square meters. The group adopts the latest and international automatic assembling lines and precise informationized management mode. It has formed an ideal system from the product researching, quality control to complete machines and parts manufacturing, sales and after-sale service. The company has passed ISO9001:2008 Quality Authentication, ISO14001:2004 Environmental Management System Certification, CE Authentication and Clean Production Certification. In 2006, Precious brand industrial sewing machine was titled with Zhengjiang Well-known Trademark and Zhejiang Well-known Product. In 2008, Precious was awarded "Credit Enterprise of Zhejiang Province", "AAA Credit and Reliability Unit by Agricultural Bank". In January 2009, "PRECIOUS" brand was titled with China Well-known Trademark. In 2010, Precious company was identified as National High-Tech Enterprise, Science and Technology Enterprise in Zhejiang Province. In 2011, Precious was awarded China Sewing Machinery Industry Vanguard Industry Enterprise and Provincial High And New Thechology Research And Development Center. In 2012, the company was named National Torch Program Industrialization Demonstration Project Enterprise, Zhejiang Honoring Contracts and Credit AAA Enterprise and the Well-known Firm. For four consecutive years of 2013-2016, Precious was awarded China Sewing Machinery Industry Top 10 Enterprises, China Light Industry Growth Ability Top 100 Enterprises, and the Safety Production Standardization National Secondary Enterprise.

We always insist that science and technology innovation as the development motive, international brand as the pursuit goal, with the strategic concept of "first precise, then strong, finally to be large", adhering to the core concept of "creating, enjoying and developing together", paying equal attention to domestic and foreign markets, focusing on both developed country and developing country. Hope that through our efforts, can create value for customer and provide value-add services. We are looking forward to working with you to create the brilliancy together.



## SYMBOLS 图示符号一览表



平板式  
Flat bed



线数  
No. of threads



上下送料  
Top and bottom feed



薄料  
Light-weight material



滚轮压脚  
Roller presser foot



切达宽度  
Width of Edge cutting



平台式  
Flat bed



线迹型式  
Style



综合送料  
Unison feed



中厚料  
Medium-weight material



加固缝  
Straight line bartacking



切布厚度  
Thickness of Cloth cutting



箱体式  
Box type



机针  
Needle



上差动牙行程  
On the differential travel



厚料  
Heavy-weight material



挡线  
Thread wiper



缝距调节方式  
Mode of Adjustment in sewing space



立柱式  
Post bed



针间距  
Needle gauge



针数  
No. of needles



细线  
Thin thread



切线  
Thread trimmer



按钮式  
Button type adjustment



悬筒式  
Cylinder type



不锈钢  
Stainless steel



缝纫速度  
Sewing speed



中线  
Medium thread



纽扣直径  
Button diameter



前后针间距  
Needle gauge



裁剪刀  
Cutter Scissors



用途  
Function



缝纫速度  
(带速度控制器)  
Sewing speed  
(with controller)



粗线  
Heavy thread



钉扣形式  
Attaching form



针摆幅度  
Amplitude of needle fluctuation



卧式标准旋梭  
Horizontal hook  
(standard)



针迹长度  
Stitch length



压脚提升量  
Lift of the presser foot



特粗线  
Special heavy thread



倒回缝  
Reverse stitching



图形转换  
Diagram conversion



卧式双倍旋梭  
Horizontal hook  
(large)



线迹长度  
Stitch length



主运动量  
Main feed amount



极厚料  
Extra heavy-weight material



交替幅度  
Alternation range



套结长度  
Bar-lacking length



立式标准旋梭  
Vertical hook  
(standard)



线迹宽度  
Stitch width



差动比  
Differential ratio



电机  
Motor



弯针  
Looper



套结宽度  
Bar-lacking width



立式双倍旋梭  
Vertical hook  
(large)



下送料  
Bottom feed



差动主运动量  
Differential feed amount



离合式针杆  
Split needle bar



拨针  
Catcher



双针间距  
Twin Needle Gauge



摆梭  
Shuttle hook



差动送料  
Differential feed



差动量比  
Differential ratio



针杆行程  
Needle stroke



模式  
Sewing mode



mm



电子夹线器  
Electronic thread tension



针送料  
Needle feed



刀  
Cutlery



滚轮送料  
Wheel feed



布切刀  
Cloth blade



净重/毛重  
Net/gross weight



## 目 录

### CATALOGUE

#### 企业篇 COMPANY

|                          |    |
|--------------------------|----|
| 汇宝品牌PRECIOUS BRAND       | 01 |
| 品质闪耀PRECIOUS TECHNOLOGY  | 03 |
| 企业简介COMPANY INTRODUCTION | 05 |

#### 平缝机系列

##### HIGH-SPEED LOCKSTITCH SEWING MACHINE SERIES

|                      |    |
|----------------------|----|
| G20                  | 09 |
| PC9897               | 11 |
| PC9893               | 12 |
| PC7200B              | 13 |
| PC9895G-D4           | 14 |
| PC8700/PC8500        | 15 |
| PC7340/PC6150/PC202  | 16 |
| PC9807/PC9817/PC9827 | 17 |
| PC8521D/PC8520       | 18 |
| PC9622A              | 19 |
| PC9612A              | 20 |
| PC9317               | 21 |
| PC9322               | 22 |
| PC9312               | 23 |
| PC0303D              | 24 |

#### 双针平缝机系列

##### DOUBLE-NEEDLE LOCKSTITCH SEWING MACHINE SERIES

|  |    |
|--|----|
| PC20618-2DQ/PC20618                      | 25 |
| PC20518/PC20528                          | 26 |
| PC8842/8872/8845/8875                    | 27 |
| PC8420D/UT 8720D/UT 8450D/UT<br>8750D/UT | 28 |

#### 包缝机 OVERLOCK SEWING MACHINE SERIES

|                                   |    |
|-----------------------------------|----|
| V20                               | 29 |
| PC5200D-EX-4UT                    | 31 |
| PC5200D-EXT-4UT                   | 32 |
| PC5100D-EX                        | 33 |
| PC5100D-EXT                       | 34 |
| PC700D-3/4/5UT PC700-3/4/5        | 35 |
| PC700-4-BK PC700-4-55A PC700-4-CQ | 36 |
| PC700D-02x250 PC700D-5-48         |    |
| PC700D-6KH-CQ                     | 37 |
| PC797D-3/4/5UT PC797-3/4/5        | 38 |
| PC747D                            | 39 |
| PC737M PC717M                     | 40 |

#### 绷缝机系列 INTERLOCK SEWING MACHINE SERIES

|                        |    |
|------------------------|----|
| F20                    | 41 |
| PC31016D-01CB/UT(W500) | 43 |
| PC31026D-01/UT         |    |
| PC31026D-35ZD/UT/CQ    | 44 |

#### 多针机系列 MULTI NEEDLES MACHINE SERIES

|                      |    |
|----------------------|----|
| PC008-04/08/13/17/23 | 45 |
| PC008-12064VPQ       | 46 |
| PC1302               | 47 |
| PC1508P 1404P        | 48 |

#### 特种机系列 SPECIAL SEWING MACHINE SERIES

|                     |    |
|---------------------|----|
| PC313-90/105        | 49 |
| PC982               | 50 |
| PC1790N             | 51 |
| PC1790              | 52 |
| PC781D/781          | 53 |
| PC1900A             | 54 |
| PC1903AS            | 55 |
| PC1377D/373         | 56 |
| PC927               | 57 |
| PC928               | 58 |
| PC2290/2284         | 59 |
| PC20U               | 60 |
| PC20058             | 61 |
| PC2182              | 62 |
| PC388               | 63 |
| PC6699              | 64 |
| PC6200D-01-MR-AT/AW | 65 |
| PC910/920           | 66 |
| PC9910D/9920D       | 67 |
| PC450/600           | 68 |
| PC818               | 69 |
| PC500/600 PC861     | 70 |
| PC26-1              | 71 |
| PC-T3/PC103         | 72 |
| 汇宝电脑绣花机             | 73 |



# PRECIOUS®

## G20 智能一体平缝机

Smart mechanical & electrical integrated lockstitch sewing machine

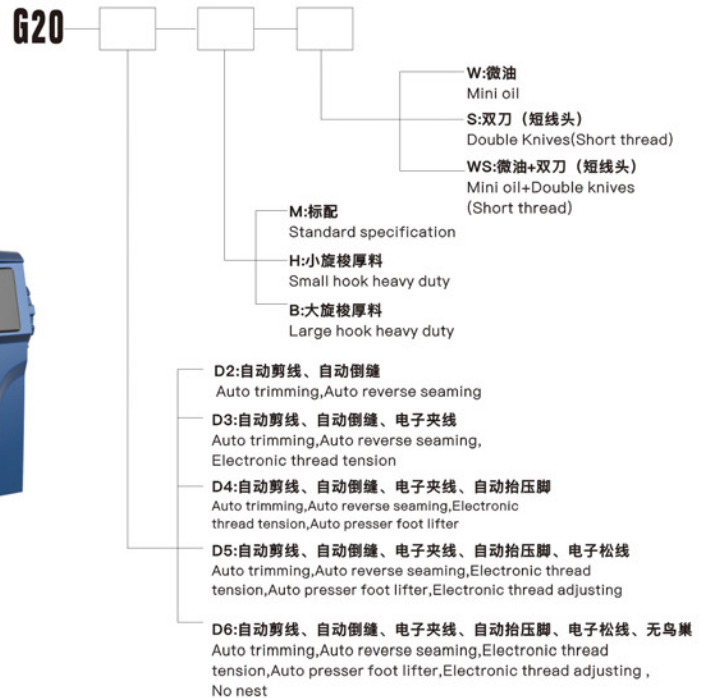

### 用途:

适用于运动衫、衬衫、夹克、西装西裤、T恤、裙子、牛仔裤、外衣等一般薄料、中厚料缝制。

### 特点:

- 1.前瞻欧洲工业设计理念。
- 2.人性化触控操作屏，实现人机交互。
- 3.创新通轴设计，缝纫更顺畅。
- 4.起缝无鸟巢，结束短线头，减少后处理工作量。
- 5.优化挑线机构，实现薄厚通吃，一机多用。
- 6.多功能高集成组合开关，操作更简便。
- 7.电子松线的优化，线迹更美观。
- 8.智能一体，节能高效。

### Application:

Applicable to thin material and medium heavy material such as sweatshirts, shirts, jackets, suit trousers, T-shirts, skirts, jeans and coats etc.

### Features:

1. Combining European industrial design concept.
2. Humanized touch screen operation, to achieve human-computer interaction.
3. Innovative through the shaft design, sewing more smoothly.
4. Starting without nest, the end of short thread, reduce the workload of post-processing.
5. Optimize the thread take-up mechanism, applicable for both thin and heavy material, one machine multi use.
6. Multi-function high integration combination switch, easier operation.
7. Optimize electronic thread tension, stitch more beautiful.
8. Mechanical & electronic Integrated, energy saving and efficient.



|          |                 |   |   |   |      |   |   |      |   |   |   |   |       |             |
|----------|-----------------|---|---|---|------|---|---|------|---|---|---|---|-------|-------------|
| G20-D4M  | DBX1<br>11#-18# | 2 | ★ | 5 | 5/13 | ★ | — | 5000 | ★ | ★ | ★ | ★ | 48/50 | 705×255×580 |
| G20-D4B  | DPX5<br>18#-21# | 2 | ★ | 7 | 5/13 | — | ★ | 3500 | ★ | ★ | ★ | ★ | 48/50 | 705×255×580 |
| G20-D4XM | DBX1<br>11#-18# | 2 | ★ | 5 | 5/13 | ★ | — | 5000 | ★ | ★ | ★ | ★ | 48/50 | 705×255×580 |
| G20-D4H  | DBX5<br>18#-21# | 2 | ★ | 7 | 5/13 | ★ | — | 3500 | ★ | ★ | ★ | ★ | 48/50 | 705×255×580 |



## G20 产品优势

### Advantages



**1** 设计起缝无鸟巢机构，实现面料底部线迹更美观。  
The design of no nests structure, to achieve a more beautiful fabric design at the bottom.



**2** 智能触控，简单直观。  
Smart touch screen, simple and intuitive.



**3** 自由设置，一键恢复，语音提示，一键直达，按键式操作盒（可选）。  
Free set, a key recovery, voice prompts, a key to complete, push button (optional).



**4** 数字发光旋钮，新颖、时尚、动感。  
Digital light knob, novel, stylish, dynamic.



**5** USB智能端口，为USB产品供给持续电量，还可升级电控程序。  
USB smart connection, supply continuous power for USB product, also upgrade the electronic control program.



**6** 集补针、点动倒缝、LED灯于一体，操作更轻松。  
Add stitches, touch reverse seaming, LED light in one, easier to operate.



**7** 电子脚靠，不改变原来的操作习惯，实现轻松抬压脚。  
Electronic knee lifting, remain the original operating habits, easy foot lifting.



**8** 优化挑线机构，实现薄厚通吃。  
Optimize the thread take-up structure, applicable for both thin and heavy material.



**9** 头部无油，清洁环保。  
The head no oil, clean and environmental.



**10** 电子松线，杜绝夹线器不回弹，达到完美线迹。  
Electronic loose thread, to prevent the gripper does not rebound, to achieve the perfect stitch.

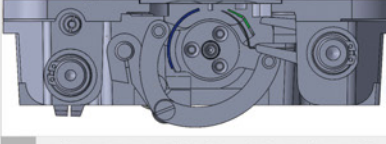

**11** 创新双圆刀切线机构，解决了人工对线头后处理的工作量，效率提高。  
Innovative double round knife trimmer structure, avoid workload of threading re-dealing, improve efficiency.



**12** 通轴创新设计，缝纫更顺畅。  
Through the axis of innovative design, sewing more smoothly.





# PRECIOUS®

## PC9897 机电一体电脑高速平缝机

Mechanical & electrical integrated computer controlled high-speed lockstitch sewing machine



### PC9897

无:标配  
Standard specification

H:厚料小旋梭  
Small hook heavy duty

D2:自动剪线、倒缝  
Auto trimming, Auto reverse seaming

D3:自动剪线、倒缝、电子夹线  
Auto trimming, Auto reverse seaming,  
Electronic thread tension

D4:剪线、倒缝、电子夹线、自动抬压脚  
Auto trimming, Auto reverse seaming,  
Electronic thread tension,  
Auto presser foot lifter

### PC9897-D4



内置抬压脚  
Inbuilt foot lifter



少鸟巢功能  
Electronic thread tension



针距标盘锁功能  
Stitch length dial lock function

#### 用途:

适用于各种服装、针织品、制服、工作服、窗帘等一般薄料、中厚料的缝制。

#### 特点:

- 1.视觉独特,外形稳重。
- 2.震动更小,噪音更低。
- 3.缝薄过厚,性能优越。
- 4.创新针距旋钮,锁紧更可靠。
- 5.一体设计,操作简便。

#### Application:

Applicable to thin and medium heavy material such as all kinds of clothing, knitwear, uniforms, working clothes and curtains etc.

#### Features:

1. Visual unique, stable shape.
2. Smaller vibration, lower noise.
3. Thin to heavy material, superior performance.
4. Innovative stitch length dial, locking more reliable.
5. Integrated design, easy to operate.

| PC9897-D4  | DBX1<br>11#-18# | 2 | ★ | 5 | 5/13 | ★ | 5000 | ★ | ★ | ★ | ★ | ★ | 41/43 | 705×255×580 |
|------------|-----------------|---|---|---|------|---|------|---|---|---|---|---|-------|-------------|
| PC9897-D4H | DBX1<br>11#-18# | 2 | ★ | 7 | 5/13 | ★ | 5000 | ★ | ★ | ★ | ★ | ★ | 41/43 | 705×255×580 |



# PRECIOUS®

## PC9893 机电一体电脑高速平缝机

Mechanical & electrical integrated computer controlled high-speed lockstitch sewing machine



PC9893

- 无标配  
Standard specification
- H:厚料小旋梭  
Small hook heavy duty

- D:单定针  
Needle positioner
- D2:自动剪线、自动倒缝  
Auto trimming, Auto reverse seaming
- D3:自动剪线、自动倒缝、电子夹线  
Auto trimming, Auto reverse seaming, Electronic thread tension
- D4:自动剪线、自动倒缝、电子夹线、自动抬压脚  
Auto trimming, Auto reverse seaming, Electronic thread tension, Auto presser foot lifter



PC9893D direct drive with needle positional



通轴创新设计  
Through the axis of innovative design

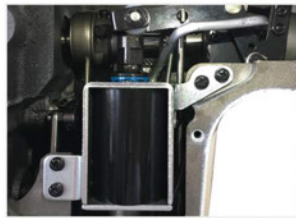

内置抬压脚  
Inbuilt foot lifter



停针位可调  
Needle position, easy to adjust



LED灯  
LED light

PC9893D

### 用途:

适用于各种服装、针织品、制服、工作服、窗帘等一般薄料、中厚料的缝制。

### 特点:

- 1.全新工业设计, 新的视觉感受。
- 2.通轴创新设计, 降低整机力矩, 缝纫更顺畅。
- 3.优化挑线机构, 薄厚缝绉无忧。
- 4.集成内置式抬压脚, 工作效率提高。
- 5.一体式的完美组合, 更节能高效。

### Application:

Applicable to thin and medium heavy material such as all kinds of clothing, knitwear, uniforms, working clothes and curtains etc.

### Features:

1. New industrial design, new visual experience.
2. Through the shaft innovative design, reduce the machine torque, sewing more smoothly.
3. Optimize the thread take-up institutions, applicable for both thin and heavy material.
4. Integrated built-in presser foot lifter, work efficiency.
5. Mechanic & electronic integrated combination, more energy saving and efficient.



| Model      | Needle          | Foot | Sawtooth | Arrow | mm   | Motor | Speed | Trimming | Reverse | Thread | Auto | kg    | mm          |
|------------|-----------------|------|----------|-------|------|-------|-------|----------|---------|--------|------|-------|-------------|
| PC9893D    | DBX1<br>11#-18# | 2    | ★        | 5     | 5/13 | ★     | 5000  | —        | —       | —      | —    | 41/43 | 705×255×580 |
| PC9893-D4  | DBX1<br>11#-18# | 2    | ★        | 5     | 5/13 | ★     | 5000  | ★        | ★       | ★      | ★    | 41/43 | 705×255×580 |
| PC9893-D4H | DBX1<br>11#-18# | 2    | ★        | 7     | 5/13 | ★     | 3500  | ★        | ★       | ★      | ★    | 41/43 | 705×255×580 |



**PRECIOUS®**

# PC7200B 直驱微油电脑高速平缝机

Computer controlled direct drive high-speed lockstitch sewing machine with mini oil



采用圆刀结构  
Round cutter structure



外置抬压脚(可选配)  
External auto foot lifter (Optional)



PC7230B 厚料大旋梭  
PC7230B Heavy duty large hook

## PC7200B-

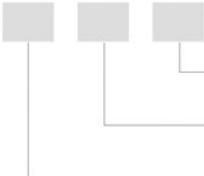

- |             |   |
|-------------|---|
| S:用于薄料、难缝布料 | S.For light material, difficult sewing material |
| 3:用于中厚料     | 3.For medium heavy material                     |
| 5:用于厚料      | 5.For heavy material                            |
| 0:微油型       | 0.Mini oil type                                 |
| 3:针杆无油型     | 3.Oilless needle bar type                       |
| 5:无油型       | 5.Oilless type                                  |
| 3:切线+倒缝     | 3.Auto trimmer+reverse seaming                  |
| 4:切线+倒缝+扫线  | 4.Auto trimmer+reverse seaming+thread wipe      |

### 用途:

适用于针织、衬衫、西服、牛仔等中厚料的缝制。

### 特点:

- 1.采用直接驱动系统, 振动、噪音低于目前任何一款电脑平缝机。
- 2.比普通电机省电60%左右, 比变频伺服马达省电30%以上。
- 3.采用密封油箱, 持续为旋梭提供干净的机油, 也可使用无油旋梭, 不再需要为旋梭提供润滑油。
- 4.采用高速静音轴承, 同步带传动, 运行平稳, 线迹美观, 收线干净整齐。
- 5.采用同步带传动, 传动平稳, 噪音低振动小。

### Application:

Suitable for knitting, shirts, suits, jeans and other medium heavy material sewing.

### Features:

1. Direct-drive system best for lockstitch sewing, vibration and noise are lower than any item of sewing machine nowadays.
2. High power-saving: Save about 60% of energy compared with the common motors, 30% up with frequency servo motor.
3. Sealed oil box provides the hook with clean oil continuously, or adopt oilless hook, which needn't lubrication.
4. The machine adopted high-speed silent bearing, synchronous belt drive, make the machine runs smoothly, beautiful stitches and take the line clean and tidy.
5. Adopting synchronous belt drive, smooth transmission, low noise and low vibration.

| PC7200B-433/-D4 | DB×1<br>11# - 18# | 2 | ★ | 5 | 6/13 | ★ | — | 5000 | ★ | ★ | ★ | 9-11 | 46/52 | 690×315×670 |  |
|-----------------|-------------------|---|---|---|------|---|---|------|---|---|---|------|-------|-------------|--|
| PC7230B/D4      | DB×1<br>11# - 18# | 2 | ★ | 5 | 6/13 | — | ★ | 3500 | ★ | ★ | ★ | 9-11 | 46/52 | 690×315×670 |  |



# PRECIOUS®

## PC9895G-D4 机电一体电脑长臂平缝机

Mechanical & electrical integrated long-arm computerized lockstitch sewing machine



模板  
Templet



拖布轮 气动、电动(可选)  
Pulley pneumatic or  
power-driven(optional)

### 用途:

- 1.适用于大物件的缝制。
- 2.配置滚轮式压脚可满足模板作业。

### 特点:

- 1.具有宽大的机头空间，有利于各种大物件的缝制。
- 2.一体化机头与控制系统的完美结合，安装使用更方便。
- 3.站立式可移动控制器，操作更方便。
- 4.配备电子拖布轮，轻松进行模具化缝制，品质更佳。

### 机器配置说明:

- 1.操作空间可选:  560mm  850mm
- 2.台板可选:  普通型  吸风型  钢珠型
- 3.台板尺寸可选:  1200x1500mm  1200x1800mm

### Application:

1. It is applicable for large item.
2. Assemble the roller presser foot be satisfied with mould task.

### Features:

1. With large head space, it is suitable for variety of large items of sewing.
2. The integration of the head and the perfect combination of control systems, installation and use more convenient.
3. Vertical movable controller, the operation more convenient.
4. Assemble electronic puller, easy to mould sewing, better quality.

### Machine specifications:

1. Optional working space:  560mm  850mm
2. Optional table:  Normal type  Air type  Steel ball type
3. Optional table size:  1200x1500mm  1200x1800mm

| PC9895G-D4-560 | DB×1<br>11#-18# | 2 | ★ | 4 | 5/13 | ★ | 3000 | ★ | ★ | ★ | ★ | 70/80  | 108×325×645 |
|----------------|-----------------|---|---|---|------|---|------|---|---|---|---|--------|-------------|
| PC9895-D4-850  | DB×1<br>11#-18# | 2 | ★ | 4 | 5/13 | ★ | 3000 | ★ | ★ | ★ | ★ | 90/100 | 130×325×645 |



# PRECIOUS®

## PC8700 / PC8500 高速平缝机

High-speed lockstitch sewing machine

出口专供  
Exporting only



PC8700



PC8500

线迹图例



**用途:**  
适用于各种服装、针织品、薄料、中厚料的缝制。

**特点:**  
自动加油润滑、针距调节和反缝简捷，性能杰出、经久耐用。

**Application:**  
Applicable to different kinds of garments, knitted fabric, thin, medium-heavy material.

**Features:**  
Automatically with oil lubrication, adjustment of needle gauge and simplicity of reverse seaming. It is an excellent durable level seaming machine.

| Model               | Needle                | Stitch | Star | Reverse | Foot   | Bobbin | Thread | Speed | Weight | Dimensions  |
|---------------------|-----------------------|--------|------|---------|--------|--------|--------|-------|--------|-------------|
| PC8700/8500         | DB×1<br>14# (9#-18#)  | 2      | ★    | 5       | 5.5/13 | ★      | —      | 5000  | 33/35  | 570×250×540 |
| PC8700H/8500H       | DB×1<br>18# (14#-18#) | 2      | ★    | 5       | 5.5/13 | ★      | —      | 4000  | 33/35  | 570×250×540 |
| PC8700H-7/8500H-7   | DB×1<br>21# (19#-23#) | 2      | ★    | 7       | 5.5/13 | ★      | —      | 4000  | 33/35  | 570×250×540 |
| PC8700XH-8/8500XH-8 | DB×1<br>21# (18#-23#) | 2      | ★    | 8       | 5.5/13 | —      | ★      | 3000  | 33/35  | 570×250×540 |



# PRECIOUS®

## PC7340/PC6150 高速平缝机 PC202 高速厚料平缝机(大旋梭)

PC7340/PC6150 High-speed lockstitch sewing machine  
PC202 High-speed heavy duty lockstitch sewing machine (Large hook)



PC7340



PC202



PC6150

出口专供  
Exporting only

线迹图例



**用途:**  
适用于服装、针织、皮革等薄、中、厚料缝纫。

**特点:**  
自动加油润滑、线迹美观、高效、低噪音、低振动。

**Application:**  
Applicable to kinds of garments, knitted fabric, leather and so on. Thin, medium-heavy material.

**Features:**  
Automatically with oil lubrication, beautiful stitch, high speed, high efficiency, low noise with little vibration.

|        |                      |   |   |   |        | mm |   |      |       | kg          | mm |
|--------|----------------------|---|---|---|--------|----|---|------|-------|-------------|----|
| PC7340 | DB×1<br>14# (9#-18#) | 2 | ★ | 5 | 5.5-13 | ★  | — | 5000 | 33/35 | 570×250×540 |    |
| PC6150 | DB×1<br>14# (9#-18#) | 2 | ★ | 5 | 5.5-13 | ★  | — | 5000 | 33/35 | 570×250×540 |    |
| PC202  | DP×5<br>22#          | 2 | ★ | 8 | 6-13   | —  | ★ | 3500 | 33/35 | 570×250×540 |    |



**PRECIOUS®**

**PC9807 机电一体电脑带侧切刀高速平缝机**

**PC9817 机电一体电脑针送布高速平缝机**

**PC9827 机电一体电脑针送布带侧切刀高速平缝机**

**Mechanical & electrical integrated computer controlled high-speed lockstitch sewing machine with edge cutter**

**Mechanical & electrical integrated computer controlled needle feed high-speed lockstitch sewing machine**

**Mechanical & electrical integrated computer controlled needle feed high-speed lockstitch sewing machine with edge cutter**



PC9817-D4



PC9807-D4 PC9827-D4



切刀  
Cutter



内置抬压脚  
Inbuilt foot lifter



采用圆刀结构  
Round cutter structure

**PC9807-D4 用途:**

适用于衬衣、童装、床上用品、家居布艺饰品、休闲服装等的缝制。

**特点:**

1. 优化切刀同异步，不更换零件，可自如切换。
2. 电子夹线，控制鸟巢。
3. 内置式抬压脚，效率更高。
4. 一体化组合，振动更小，噪音更低。

**PC9817-D4 PC9827-D4 用途:**

适用于高品质的缝纫工序，易滑布料、重叠布料，如运动衣、雨衣、裙子、休闲衣裤、窗帘、裤子等难缝布料的缝制。

**特点:**

1. 外形稳重，做工精良。
2. 针牙送料，杜绝缝纫错位。
3. 集成内置抬压脚，效率更高。
4. 电子夹线，线迹美观。
5. 一体组合，品质更佳。

**PC9807-D4 Application:**

Applicable to shirt, children wear, bedding article, home decoration, casual wear and other sewing.

**Features:**

1. Optimize the cutter with synchronism and asynchronism, do not replace parts, more convenient operation.
2. Electronic thread tension, control the under thread.
3. Inbuilt foot lifter, more efficient.
4. Integrated combination, smaller vibration, lower noise.

**PC9817-D4 PC9827-D4 Application:**

Applicable to high-quality sewing process, easy to slip fabric, overlapping fabrics, such as sportswear, raincoat, skirt, leisure clothing, curtains, pants and other sewing materials sewing.

**Features:**

1. Steady shape, excellent workmanship.
2. Needle feeding, to prevent sewing dislocation.
3. Integrated inbuilt foot lifter, more efficient.
4. Electronic thread tension, beautiful stitch.
5. Mechanical and electronic integrated, better quality.



PC9807-D4

DB×1  
11#-18#

2

★

1/8 3/16  
1/4

5

5/13

★

4500

★

★

★

★

41/43

705×255×580

PC9817-D4

DB×1  
11#-8#

2

★

—

4

5/13

★

4500

★

★

★

★

41/43

705×255×580

PC9827-D4

DB×1  
11#-8#

2

★

1/8 3/16  
1/4

4

5/13

★

4500

★

★

★

★

41/43

705×255×580



# PRECIOUS®

## PC8521D 直驱单定针切包一体高速平缝机

## PC8520 高速单针带刀平缝机

PC8521D Direct drive high speed single needle lockstitch sewing machine with bound edge cutter

PC8520 High speed single needle lockstitch sewing machine with edge cutter



PC8521D



PC8520



切包一体  
Bound edge cutter



吸风装置  
Suction

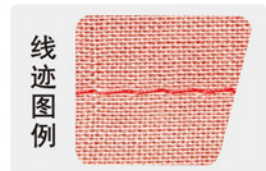

### PC8521D 用途:

适用于各类衬衫、西服、服装衣领、前襟等部位的缝制。

### 特点:

- 1.性能稳定顺畅，切刀锋利，操作简易、高效。
- 2.低振动、低噪音。
- 3.采用内置式直驱伺服马达，反应迅速，停针准确，无电控箱，比普通电机省电60%。
- 4.在缝制的同时，完成布料的切边工序和包边工序，大大提高工作效率。

PC8520 用途: 适用于针织品、衬衫、西服、休闲服、牛仔等薄料、中厚料缝制。

### 特点:

- 1.在缝制的同时，完成布料的切边工序。
- 2.线迹美观、切边整齐。
- 3.可供选择多种规格的切刀片。

### PC8521D Application:

Applicable to all kinds of shirt, suit, clothing collar, front lapel and other parts of the sewing.

### Features:

- 1.Stable and smooth performance, sharp knife, easy to operate and efficient.
- 2.Low vibration, low noise.
- 3.Adopt inbuilt direct drive servo motor, rapid response, needle position accurately, no electric control box, save power 60% less than the clutch motor .
- 4.In the meantime of sewing, complete the fabric edge cut and bound process, greatly improve work efficiency.

### PC8520 Application:

Applicable to knit fabric, shirt, suit, casual cloth, jean and thin,medium and heavy material.

### Features:

- 1.In the meantime of sewing, complete the fabric edge cutter process.
- 2.Beautiful stitch, clearly edge cutter.
- 3.To select variety of specifications of the cutter.



PC8521D

DB×1  
(11# - 18#)

2

★

1/8 3/16 1/4

4

5/13

★

5000

33/35

570×250×535

PC8520

DB×1  
(11# - 18#)

2

★

1/8 3/16 1/4

5

5/13

★

3500

33/35

570×250×535





# PRECIOUS®

## PC9622A 智能一体综合送料厚料平缝机

Smart mechanical & electrical Integrated compound feed heavy duty lockstitch machine



PC9622A

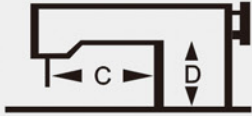

C:365mm D:150mm

超大操作空间  
Huge operate space



HP装置 (可调交互量, 轻松上下坡)  
HP device (Adjustable alternation,easy sewing)



综合送料  
Compound feed



新连杆机构 (杜绝提升压脚上下不灵活现象)  
New connecting rod mechanism (Put an end to the flexible operatirity of foot lift up and down )



内置抬压脚  
Inbuilt foot lifter

### 用途:

适用于汽车内饰及家具软装潢、箱包、鞋类加工的理想缝制。

### 特点:

- 1.首创在上下复合送料机上设计针牙、交替压脚同步送料机构,确保面料无忧输送且无位移的效果,使缝制品更美观。
- 2.创新设计的机身,可操作空间长达365mm,高150mm,解决了大件物料的缝制。
- 3.首创压脚提升轴和压脚摆动轴全密封设计在机壳内腔。
- 4.首创的集成内置式抬压脚装置。
- 5.优化的便捷式窗口,方便工人调整压脚交互量。

### Application:

Applicable to interior of the automobile and furniture flexible decoration, luggage, footwear processing the ideal sewing.

### Features:

- 1.The first base of top and bottom feed machine design needle, alternating pressure foot synchronous feeding instruction, to ensure that the fabric easy to delivery and the effect is no displacement , so that sewing products more beautiful.
- 2.Innovative design of the machine case, operable space up to 365mm, height is 150mm, to solve the large items sewing.
- 3.The first presser foot lift shaft and presser foot swing shaft full seal design in the case's chamber.
- 4.The first integrated inbuilt foot lifter device.
- 5.Optimize the convenience of the window,the workers adjust pressure foot alternative range more convenient.



PC9622A-D4

DP×17  
11#-18#

2

★

3.5/5.5

8

6/13

★

2000

★

★

★

★

51/58

805×255×580

PC9622A-D4HP

DP×17  
11#-18#

2

★

3.5/5.5

8

6/13

★

2000

★

★

★

★

51/58

805×255×580



# PRECIOUS®

## PC9612A 智能一体综合送料厚料平缝机

Smart mechanical & electrical Integrated compound feed heavy duty lockstitch machine



PC9612A



HP装置 (可调交互量, 轻松上下坡)  
HP device (Adjustable alternative range , easy sewing)



综合送料  
Compound feed



新连杆机构 (杜绝提升压脚上下不灵活现象)  
New connecting rod mechanism  
(Put an end to the flexible operatillity of foot lift up and down )



内置抬压脚  
Inbuilt foot lifter

### 用途:

适用于汽车内饰及家具软装潢、箱包、鞋类加工的理想缝制。

### 特点:

1. 首创在上下复合送料机上设计针牙、交替压脚同步送料机构, 确保面料无忧输送且无位移的效果, 使缝制品更美观。
2. 首创压脚提升轴和压脚摆动轴全密封设计在机壳内腔。
3. 首创的集成内置式抬压脚装置。
4. 机头与控制系统全新一体化设计, 提高了效率。
5. 优化的便捷式窗口, 方便工人调整压脚交互量。

### Application:

Applicable to interior of the automobile and furniture flexible decoration, luggage, footwear processing the ideal sewing.

### Features:

1. The first base of top and bottom feed machine design needle, alternating pressure foot synchronous feeding instruction, to ensure that the fabric easy to delivery and the effect is no displacement , so that sewing products more beautiful.
2. The first presser foot lift shaft and presser foot swing shaft full seal design in the case's chamber.
3. The first integrated inbuilt foot lifter device.
4. Head and control system new integrated design, improve efficiency.
5. Optimize the convenience of the window,The workers adjust pressure foot alternative range more convenient.



PC9612A-D4

DP×17  
11#-18#

2

★

3.5/5.5

8

6/13

★

2200

★

★

★

★

41/43

705×255×580

PC9612A-D4HP

DP×17  
11#-18#

2

★

3.5/5.5

8

6/13

★

2200

★

★

★

41/43

705×255×580



# PRECIOUS®

## PC9317 智能一体带侧切刀上下复合送料厚料平缝机

Smart mechanical & electrical integrated top and bottom feed heavy duty lockstitch machine with edge cutter



切刀  
Cutter



内置抬压脚  
Inbuilt foot lifter

线迹图例

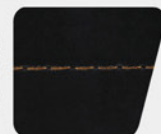

### 用途:

适用于皮革、人造革、箱包、座垫、帐篷、沙发、鞋类、布袋、手套、钱包等织带物品的缝制。

### 特点:

- 1.造型稳重美观，操作空间大。
- 2.在缝纫的同时，完成布料的切边工序，线迹稳定，切边整齐。
- 3.首创压脚提升轴和压脚摆动轴全密封设计在机壳内腔。
- 4.首创的集成内置式抬压脚装置。
- 5.机头与控制系统全新一体化设计，提高了效率。

### Application:

Applicable to sew leather, artificial leather, case, cushions, tents, sofas, footwear, bags, gloves, wallet and other items.

### Features:

- 1.Stable and beautiful shape, large operating space.
- 2.Sewing and fabric cutting at the same time, stitch stable, trimming neatly.
- 3.Initial presser foot lift shaft and presser foot swing shaft seal design in the case cavity.
- 4.Initial integrated built-in foot lifting device.
- 5.Head and control system of the new integrated design, improve efficiency.

| PC9317-D2 | DP×17<br>11#-18# | 2 | ★ | 3/16 1/4<br>5/16 | 8 | 6/13 | ★ | 2200 | ★ | ★ | — | — | 41/43 | 705×255×580 |  |  |  |
|-----------|------------------|---|---|------------------|---|------|---|------|---|---|---|---|-------|-------------|--|--|--|
| PC9317-D3 | DP×17<br>11#-18# | 2 | ★ | 3/16 1/4<br>5/16 | 8 | 6/13 | ★ | 2200 | ★ | ★ | ★ | — | 41/43 | 705×255×580 |  |  |  |
| PC9317-D4 | DP×17<br>11#-18# | 2 | ★ | 3/16 1/4<br>5/16 | 8 | 6/13 | ★ | 2200 | ★ | ★ | ★ | ★ | 41/43 | 705×255×580 |  |  |  |



**PRECIOUS®**

## PC9322 智能一体上下复合送料厚料平缝机(加长、加高)

Smart mechanical & electrical integrated top and bottom feed heavy duty lockstitch sewing machine(Enlarge the length and height)



PC9322



- 无:标配  
Standard specification
- HP:加可调交互量装置  
Adjustable alternation
- D:单定针  
Needle positioner
- D2:自动剪线、倒缝  
Auto trimming,Auto reverse seaming
- D3:自动剪线、倒缝、电子夹线  
Auto trimming,Auto reverse seaming,Electronic thread tension
- D4:剪线、倒缝、电子夹线、自动抬压脚  
Auto trimming,Auto reverse seaming,Electronic thread tension,Auto presser foot lifter
- 无:标配  
Standard specification
- A:新连杆机构  
New link mechanism

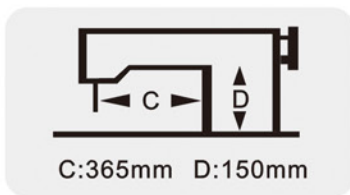

超大操作空间  
Huge operate space



HP装置 (可调交互量, 轻松下坡)  
HP device (Adjustable alternation,easy sewing)



新连杆机构 (杜绝提升压脚上下不灵活现象)  
New connecting rod mechanism (Put an end to the flexible operatility of foot lift up and down)

**用途:**

适用于皮革、人造革、箱包、座垫、帐篷、沙发、鞋类、布袋、手套、钱包等织带物品的缝制。

**特点:**

- 1.创新设计的机身, 可操作空间长达365mm, 高150mm, 解决了大件物料的缝制。
- 2.最大针距可达12mm。
- 3.首创压脚提升轴和压脚摆动轴全密封设计在机壳内腔。
- 4.首创的集成内置式抬压脚装置。
- 5.优化的便捷式窗口, 方便工人调整压脚交互量。

**Application:**

Applicable for leather, artificial leather, case, cushions, tents, sofas, footwear, bags, gloves and wallet etc.

**Features:**

- 1.Innovative design of the body, operable space up to 365mm, high 150mm, to solve the large pieces of material sewing.
- 2.Maximum needle gauge can be reached 12mm.
- 3.Presser foot lift shaft and presser foot swing shaft full seal design in the case cavity.
- 4.Integrated built-in auto foot lifter device.
- 5.Optimize the convenience of the window, to facilitate the workers to adjust the amount of pressure foot interaction.

| PC9322-D4    | DP×17<br>11#-18# | 2 | ★ | 3.5/5.5 | 8  | 6/13 | ★ | 2200 | ★ | ★ | ★ | ★ | ★ | 51/58 | 805×255×580 |
|--------------|------------------|---|---|---------|----|------|---|------|---|---|---|---|---|-------|-------------|
| PC9322-D4-12 | DP×17<br>11#-18# | 2 | ★ | 3.5/5.5 | 12 | 6/13 | ★ | 2200 | ★ | ★ | ★ | ★ | ★ | 51/58 | 805×255×580 |
| PC9322A-D4HP | DP×17<br>11#-18# | 2 | ★ | 3.5/5.5 | 8  | 6/13 | ★ | 2200 | ★ | ★ | ★ | ★ | ★ | 51/58 | 805×255×580 |



# PRECIOUS®

## PC9312 智能一体上下复合送料厚料平缝机

Smart mechanical & electrical integrated top and bottom feed heavy duty lockstitch sewing machine



PC9312

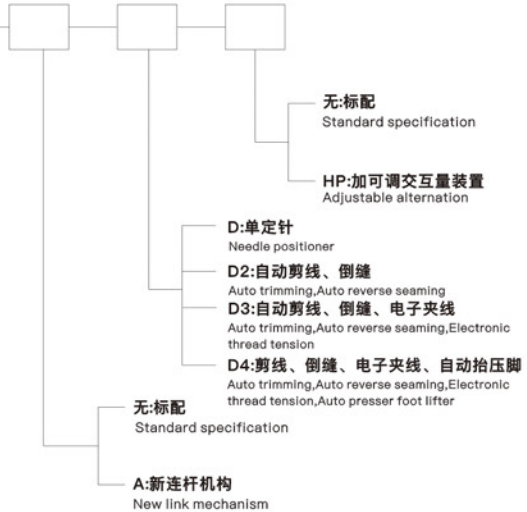

内置抬压脚  
Inbuilt foot lifter



HP装置 (可调节互量, 轻松上下坡)  
HP device (Adjustable alternation, easy sewing)



新连杆机构 (杜绝提升压脚上下不灵活现象)  
New connecting rod mechanism (Put an end to the flexible operability of foot lift up and down)

线迹图例



### 用途:

适用于皮革、人造革、箱包、座垫、帐篷、沙发、鞋类、布袋、手套、钱包等织带物品的缝制。

### 特点:

1. 简洁流畅的外观设计。
2. 最大针距可达12mm。
3. 首创压脚提升轴和压脚摆动轴全密封设计在机壳内腔。
4. 首创的集成内置式抬压脚装置。
5. 采用大功率的倒缝电磁铁, 适用于较厚缝料的前后加固。
6. 优化的便捷式窗口, 方便工人调整压脚交互量。
7. 机头与控制系统全新一体化设计, 提高了效率。

### Application:

Applicable for leather, artificial leather, case, cushions, tents, sofas, footwear, bags, gloves and wallet etc.

### Features:

1. Simple and smooth design.
2. Maximum needle gauge can be reached 12mm.
3. Presser foot lift shaft and presser foot swing shaft full seal design in the case cavity.
4. Integrated built-in auto foot lifter device.
5. Adopt high-power reverse stitch electromagnet, suitable for heavy material's reverse seaming.
6. Optimize the convenience of the window, to facilitate the workers to adjust the amount of pressure foot interaction.
7. Head and control system of the new integrated design, improve efficiency.

| PC9312-D4    | DP×17<br>11-18# | 2 | ★ | 3.5-5.5 | 8  | 6/13 | ★ | 2200 | ★ | ★ | ★ | ★ | 41/43 705×255×580 |
|--------------|-----------------|---|---|---------|----|------|---|------|---|---|---|---|-------------------|
| PC9312-D4-12 | DP×17<br>11-18# | 2 | ★ | 3.5-5.5 | 12 | 6/13 | ★ | 2200 | ★ | ★ | ★ | ★ | 41/43 705×255×580 |
| PC9312A-D4HP | DP×17<br>11-18# | 2 | ★ | 3.5-5.5 | 8  | 6/13 | ★ | 2200 | ★ | ★ | ★ | ★ | 41/43 705×255×580 |



# PRECIOUS®

## PC0303D 机电一体单定针上下复合送料厚料平缝机

Mechanical & electrical integrated top and bottom feed heavy duty lockstitch sewing machine with needle positioner



上下复合送料  
Top and bottom feed structure



压力微调  
Pressure tiny adjustment



内置绕线轮  
Built-in bobbin winder device

**用途:**  
适用于皮革、人造革、帆布、座垫、沙发、箱包等。

- 特点:**
- 1.采用连杆式上下送料机构和交替压脚提升机构，保证送料的顺畅。
  - 2.采用大功率伺服电机直驱驱动，吃厚能力更强。
  - 3.后窗板采用加高密封设计，可有效的防治渗油。
  - 4.直驱一体，操作更简便，生产效率更高。

注：PC0338为综合送料厚料平缝机

**Application:**  
Applicable to leather, artificial leather, canvas, cushions, sofas, luggage and so on.

- Features:**
1. Adopted connecting rod top and bottom feed mechanism and the alternative presser foot lifting mechanism to ensure smooth feeding.
  2. Adopted high-power servo motor direct drive, more suitable for heavy material.
  3. The rear plate with high sealing design, more effectively prevent oil leak.
  4. Integrated direct drive, the operation is more simple, more productive.

Remark: PC0338 is compound feed heavy lockstitch sewing machine

| PC0303D | DP×17<br>18-23# | 2 | ★ | — | 3.5-5.5 | 8 | 6/13 | ★ | 2200 | 33/35 | 570×250×540 |  |
|---------|-----------------|---|---|---|---------|---|------|---|------|-------|-------------|--|
| PC0303  | DP×17<br>18-23# | 2 | ★ | — | 3.5-5.5 | 8 | 6/13 | ★ | 2000 | 33/35 | 570×250×540 |  |
| PC0338  | DP×17<br>18-23# | 2 | — | ★ | 3.5-5.5 | 8 | 6/13 | ★ | 2000 | 33/35 | 570×250×540 |  |



# PRECIOUS®

## PC20618-2DQ 自动剪线双针综合送料平缝机 PC20618 综合送料平缝机

PC20618-2DQ Double-needle compound feed lockstitch sewing machine with auto trimmer  
PC20618 Compound feed lockstitch sewing machine



PC20618-2DQ



PC20618-1

### 用途:

适用于汽车坐垫、安全带、安全气囊灯汽车适件的缝制，以及帐篷、降落伞等大型器具的缝制。

### 特点:

- 1.采用大型立式旋梭勾线，滑杆挑线。
- 2.上下轴用滚针轴承支撑，同步齿形带传动，柱塞式油泵润滑系统，采用针杆摆动与压脚送布牙同步送料方式，传动轻滑，噪音小，耐用度高。

### Application:

Applicable to car cushion, seat belts, airbags and other car parts of the sewing, as well as tents, parachutes and other large equipment sewing.

### Features:

- 1.The use of large vertical hook hook line, slider take the thread.
- 2.The upper and lower shaft with a needle roller bearings support, synchronous toothed belt drive, plunger pump lubrication system, the use of needle bar swing and presser foot feed feed synchronous feeding, sliding light, low noise, high durability.

|             |                  |   |   |   | mm   |   |   |      | kg    | mm          |
|-------------|------------------|---|---|---|------|---|---|------|-------|-------------|
| PC20618-1DQ | DPX17<br>#18-#23 | 2 | ★ | 9 | 7/13 | ★ | ★ | 2000 | 47/50 | 630×260×630 |
| PC20618-2DQ | DPX17<br>#18-#23 | 4 | ★ | 9 | 7/13 | ★ | ★ | 2000 | 47/50 | 630×260×630 |
| PC20618-1   | DPX17<br>#18-#23 | 2 | ★ | 9 | 7/13 | — | ★ | 2000 | 47/50 | 630×260×630 |
| PC20618-2   | DPX17<br>#18-#23 | 4 | ★ | 9 | 7/13 | — | ★ | 2000 | 47/50 | 630×260×630 |



# PRECIOUS®

## PC20518/PC20528 高速双针平缝机

High-speed double-needle lockstitch sewing machine



PC20518



PC20528



旋梭座  
Hook set



柱塞泵润滑  
Plunger pump lubrication



双针式大旋梭  
Double needle large hook

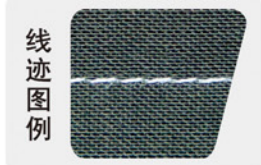

线迹图例

**用途:**  
适用于缝制衬衣、制服、大衣、女士内衣、牛仔裤等。

**特点:**  
1. 本机采用双直针，立式自动加油旋梭勾线，滑杆挑线，构成二行双锁式线迹，针杆摆动与送布同步送料，确保线迹均匀及防止缝料滑移，旋钮式圆盘调节针距和杠杆式倒送料机构使操作更为简便。  
2. 上下轴用滚针轴承支撑，同步齿形带转动，柱塞式油泵润滑系统。

**Application:**  
Applicable for sewing shirts, uniforms, coats, ladies underwear, jeans and so on.

**Features:**  
1. The machine adopts double straight needle, vertical automatic refueling hook line, slide bar thread take shape, constitute two rows of double-line lock stitch, needle bar swing and feed cloth synchronous feeding, to ensure uniform and prevent stitches sewing material, the knob-type disc adjustment pitch and lever-type feeding mechanism to make the operation more simple.  
2. The upper and lower shaft with needle bearing support, synchronous toothed belt rotation, plunger pump lubrication system.

| PC201518-M       | DPX5<br>(11#-18#) | 2 | ★ | 5 | 7/13 | ★ | — | 4000 | 47/50 | 630×260×630 |  |
|------------------|-------------------|---|---|---|------|---|---|------|-------|-------------|--|
| PC20518-H        | DPX5<br>(11#-18#) | 2 | ★ | 5 | 7/13 | ★ | — | 4000 | 47/50 | 630×260×630 |  |
| PC20518-B        | DPX5<br>(11#-18#) | 2 | ★ | 5 | 7/13 | — | ★ | 4000 | 47/50 | 630×260×630 |  |
| PC20518-M<br>大旋梭 | DPX5<br>(11#-18#) | 2 | ★ | 5 | 7/13 | ★ | — | 4000 | 47/50 | 630×260×630 |  |
| PC20528-B<br>大旋梭 | DPX5<br>(11#-18#) | 2 | ★ | 5 | 7/13 | — | ★ | 4000 | 47/50 | 630×260×630 |  |





# PRECIOUS®

## PC8842/8872/8845/8875 高速双针自动加油平缝机

### High-speed double-needle lockstitch sewing machine with auto-lubrication



PC8845/8875



PC8842/8872



PC8842H-70

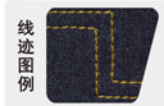

线迹图例



线迹图例

**用途:**  
适用于衬衣、制服、牛仔裤等。

- 特点:**
- 1.对缝料的适应性强,由于机针和送布牙同步送料,能防止缝料滑移。
  - 2.适用于高质量的双线迹明缝和装饰缝工艺。
  - 3.采用创新的自动加油润滑系统,使机器使用年限更长。

**Application:**  
Applicable for shirts, uniforms, jeans and so on.

- Features:**
- 1.The adaptability of the sewing material, due to the needle and feed the dog feeding simultaneously, to prevent slippage.
  - 2.Suitable for high-quality double-stitch sewing and decorative sewing process.
  - 3.The use of innovative automatic lubrication system. Make the machine longer life.

| PC8842/PC8845 | DPX5<br>11#-16# | 2 | ★ | 5 | 7/13 | ★ | — | 3500 | 42/47 | 740×350×800 |  |
|---------------|-----------------|---|---|---|------|---|---|------|-------|-------------|--|
| PC8872/PC8875 | DPX5<br>11#-16# | 2 | ★ | 7 | 7/13 | — | ★ | 3500 | 42/47 | 740×350×800 |  |



# PRECIOUS®

## PC8420D/UT 8720D/UT 8450D/UT 8750D/UT 直驱电脑自动剪线微油高速双针平缝机

Computer controlled direct drive high-speed double-needle lockstitch sewing machine  
(auto trimmer with mini oil)

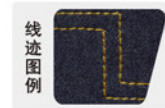

线迹图例



线迹图例

### 用途:

适用于缝制衬衣、制服、牛仔裤、大衣等薄料、中厚料的缝制。

### 特点:

- 1.采用小型伺服马达控制系统，耗电少，工作平稳，振动小，启动快速，停针准确。
- 2.采用微油供油润滑系统，能确保针杆不漏油，符合节能环保要求。
- 3.上下轴采用同步齿形带传动，运转平稳，噪音低。
- 4.采用高速静音滚蛋轴承，大大降低了转动力矩。
- 5.针牙同步带送料，防止缝料滑移。

### Application:

Suitable for sewing shirts, uniforms, jeans, coats and other thin and medium heavy material.

### Features:

- 1.The use of small servo motor control system, low power consumption, smooth work, vibration, fast start, stop needle accurate.
- 2.Micro oil supply oil lubrication system to ensure that the needle bar does not leak oil, in line with energy saving and environmental protection requirements .
- 3.The upper and lower shaft with synchronous toothed belt drive, smooth operation, low noise.
- 4.Using high-speed mute rolling bearings, greatly reducing the torque.
- 5.Needle timing belt feeding, to prevent slippage slippage.

| PC8420D/UT<br>PC8450D/UT | DBX1<br>11#-16# | 2 | ★ | 5 | 7/13 | ★ | — | 4500 | ★ | ★ | 47/42 | 705×255×580 |
|--------------------------|-----------------|---|---|---|------|---|---|------|---|---|-------|-------------|
| PC8720D/UT<br>PC8750D/UT | DPX5<br>11#-16# | 2 | ★ | 7 | 7/13 | — | ★ | 4500 | ★ | ★ | 47/42 | 705×255×580 |
| PC8420D<br>PC8450D       | DBX1<br>11#-18# | 2 | ★ | 5 | 7/13 | ★ | — | 4500 | — | — | 47/42 | 705×255×580 |
| PC8420<br>PC8450         | DBX5<br>11#-16# | 2 | ★ | 5 | 7/13 | ★ | — | 4500 | — | — | 47/42 | 705×255×580 |
| PC8720D<br>PC8750D       | DBX1<br>11#-18# | 2 | ★ | 7 | 7/13 | — | ★ | 4500 | — | — | 47/42 | 705×255×580 |
| PC8720<br>PC8750         | DBX5<br>11#-16# | 2 | ★ | 7 | 7/13 | — | ★ | 4500 | — | — | 47/42 | 705×255×580 |



# PRECIOUS®

## V20 智能一体全自动包缝机

Smart mechanical & electrical integrated full automatic overlock sewing machine



### 用途:

适用于各种薄料、中厚料、针织服装、内衣、鞋、T恤衫等织物的包边或包缝作业。

### 特点:

1. 全新工业一体化设计，效率更高。
2. 采用黑金刚针杆和滑杆，可有效防止磨损及甩油现象。
3. 智能三光眼感应装置。
4. 全自动、半自动、全手工、自由缝等多种缝纫模式。
5. 配有语音和USB智能端口。
6. 一键恢复出厂设置，轻松搞定。

### Application:

Suitable for all kinds of thin materials, medium heavy material, Knitted garments, underwear, shoes, T-shirts etc.

### Features:

1. New industrial integration design, more efficient.
2. Adopt the black diamond coating needle bar and slide bar, which can effectively prevent wear and tear oil phenomenon.
3. Intelligent three sensors device.
4. Automatic, semi-automatic, manual, free sewing and other sewing modes.
5. With voice and USB smart port.
6. One key recovery, easy operation.



**PRECIOUS®**

## V20 产品优势

### Advantages



操作面板  
Operation panel



黑金刚滑杆  
Black diamond coating slide bar

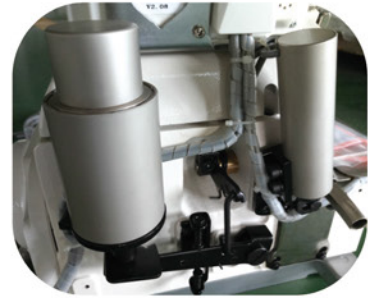

电磁铁结构  
Electromagnetic structure



三光眼  
Three sensors



斩刀结构  
Cutter structure



USB接口  
USB port

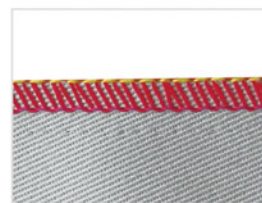
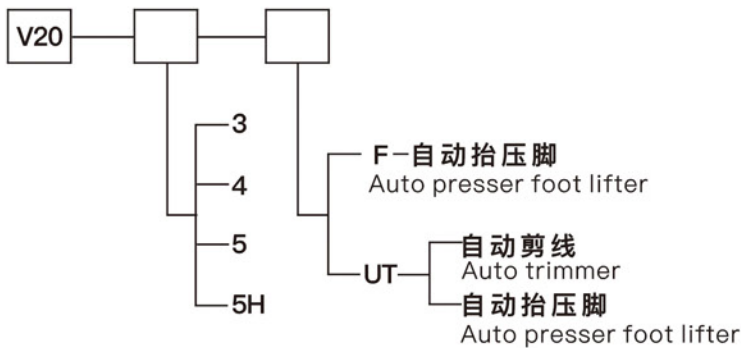

V20-3 Stitch

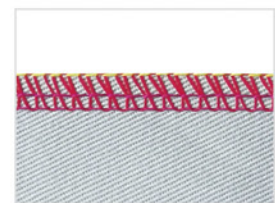

V20-4 Stitch

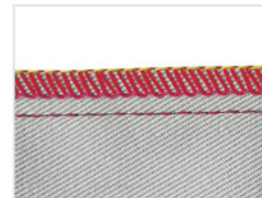

V20-5 Stitch

| V20-4   | DC×27 11# | 2 | 4 | 2 | 2.3.4 | 5.2 | 0.4-1.5 | 7000 | 5.5 | 36/38 | 525×360×510 |  |
|---------|-----------|---|---|---|-------|-----|---------|------|-----|-------|-------------|--|
| V20-4UT | DC×27 11# | 2 | 4 | 2 | 2.3.4 | 5.2 | 0.4-1.5 | 7000 | 5.5 | 36/38 | 525×360×510 |  |



# PRECIOUS®

## PC5200D-EX-4UT 直驱全自动包缝机

Direct drive full automatic overlock sewing machine



PC5200D-EX-4UT



PC5200D-EX-4UT/BK



倒回缝装置  
BK device

**用途:**

适用于各种薄料、中厚料、针织服装、内衣、鞋、T恤衫等织物的包边或包缝作业。

**特点:**

- 1.具有自动剪线、自动抬压脚、自动启动、自动停车、自动吸布屑线头功能。
- 2.适用于不同的缝制工序。
- 3.安全开关功能，有效的保障了操作安全。
- 4.采用外观精美简洁的全中文一体化操作面板，其模式转换快捷方便，一键启动。

**Application:**

Suitable for all kinds of light material, medium heavy material Knitted garments, underwear, shoes, T-shirts and other fabric wrapping sewing.

**Features:**

1. With auto trimming, auto presser foot lifter, auto starting, auto stopping, auto suction function.
2. Suitable for different sewing processes.
3. Safety switch function, effectively protect the operator's safety.
4. Consider exquisite appearance of the entire Chinese language integrated operation panel, the mode change fast and convenient conversion, one button to start.

| PC5200D-EX-3UT  | DC×27 9#  | 1 | 3 | — | 4   | 5.2 | 0.4-1.5 | 6500 | 5.5 | 33/35 | 470×360×475 |  |
|-----------------|-----------|---|---|---|-----|-----|---------|------|-----|-------|-------------|--|
| PC5200D-EX-4UT  | DC×27 11# | 2 | 4 | 2 | 6   | 5.2 | 0.4-1.5 | 6500 | 5.5 | 33/35 | 470×360×475 |  |
| PC5200D-EX-5UT  | DC×27 21# | 2 | 5 | 3 | 3×5 | 5.2 | 0.4-1.5 | 6500 | 5.5 | 33/35 | 470×360×475 |  |
| PC5200D-EX-5HUT | DC×27 21# | 2 | 5 | 3 | 5×5 | 5.2 | 0.4-1.5 | 6500 | 5.5 | 33/35 | 470×360×475 |  |
| PC5200D-EX-3    | DC×27 9#  | 1 | 3 | — | 4   | 5.2 | 0.4-1.5 | 6500 | 5.5 | 33/35 | 470×360×475 |  |
| PC5200D-EX-4    | DC×27 11# | 2 | 4 | 2 | 6   | 5.2 | 0.4-1.5 | 6500 | 5.5 | 33/35 | 470×360×475 |  |
| PC5200D-EX-5    | DC×27 21# | 2 | 5 | 3 | 3×5 | 5.2 | 0.4-1.5 | 6500 | 5.5 | 33/35 | 470×360×475 |  |
| PC5200D-EX-5H   | DC×27 21# | 2 | 5 | 3 | 5×5 | 5.2 | 0.4-1.5 | 6500 | 5.5 | 33/35 | 470×360×475 |  |
| PC5200EX-3      | DC×27 9#  | 1 | 3 | — | 4   | 5.2 | 0.4-1.5 | 6500 | 5.5 | 33/35 | 470×360×475 |  |
| PC5200EX-4      | DC×27 11# | 2 | 4 | 2 | 6   | 5.2 | 0.4-1.5 | 6500 | 5.5 | 33/35 | 470×360×475 |  |
| PC5200EX-5      | DC×27 21# | 2 | 5 | 3 | 3×5 | 5.2 | 0.4-1.5 | 6500 | 5.5 | 33/35 | 470×360×475 |  |
| PC5200EX-5H     | DC×27 21# | 2 | 5 | 3 | 5×5 | 5.2 | 0.4-1.5 | 6500 | 5.5 | 33/35 | 470×360×475 |  |



**PRECIOUS®**

## PC5200D-EXT-4UT 直驱上下差动全自动包缝机

Direct drive top and bottom differential feed full automatic overlock sewing machine



**用途:**

适用于服装、内衣、床上用品及薄形包装和皮革制品等各种面料的搭接缝、装饰缝。

**特点:**

1. 简明快捷的中英文人机操作面板，各功能一键转换。
2. 三种操作方式：全手工、半自动、全自动。
3. 双重安全开关，有效的保障了操作安全。
4. 剪线刀组斩刀模式，干净利索，使用广泛。
5. 采用上下差动送料，消除缝绉时的赶布现象。

**Application:**

Suitable for clothing, underwear, bedding and thin packaging and leather products, lap seam and decorative seaming.

**Features:**

1. Chinese and english language operation panel, with one key conversion function.
2. Three modes of operation: manual, semi-automatic, full automatic.
3. Double safety switch, effectively protect the operator's safety.
4. Cut structure, efficient and widely used.
5. Adopt the upper and lower differential feed, so that all the plies of cloth can go forward smoothly.

| PC5200D-EXT-3UT    | DC×27 9#  | 1 | 3 | — | 4   | 5.2 | 0.4-1.5 | 6500 | 5.5 | 33/35 | 470×360×475 |  |
|--------------------|-----------|---|---|---|-----|-----|---------|------|-----|-------|-------------|--|
| PC5200D-EXT-4UT    | DC×27 11# | 2 | 4 | 2 | 6   | 5.2 | 0.4-1.5 | 6500 | 5.5 | 33/35 | 470×360×475 |  |
| PC5200D-EXT-4UT/BK | DC×27 11# | 2 | 5 | 3 | 6   | 5.2 | 0.4-1.5 | 6500 | 5.5 | 33/35 | 470×360×475 |  |
| PC5200D-EXT-5UT    | DC×27 21# | 2 | 5 | 3 | 3×5 | 5.2 | 0.4-1.5 | 6500 | 5.5 | 33/35 | 470×360×475 |  |
| PC5200D-EXT-5HUT   | DC×27 21# | 2 | 5 | 3 | 5×5 | 5.2 | 0.4-1.5 | 6500 | 5.5 | 33/35 | 470×360×475 |  |
| PC5200D-EXT-3      | DC×27 9#  | 1 | 3 | — | 4   | 5.2 | 0.4-1.5 | 6500 | 5.5 | 33/35 | 470×360×475 |  |
| PC5200D-EXT-4      | DC×27 11# | 2 | 4 | 2 | 6   | 5.2 | 0.4-1.5 | 6500 | 5.5 | 33/35 | 470×360×475 |  |
| PC5200D-EXT-5      | DC×27 21# | 2 | 5 | 3 | 3×5 | 5.2 | 0.4-1.5 | 6500 | 5.5 | 33/35 | 470×360×475 |  |
| PC5200D-EXT-5H     | DC×27 21# | 2 | 5 | 3 | 5×5 | 5.2 | 0.4-1.5 | 6500 | 5.5 | 33/35 | 470×360×475 |  |
| PC5200EXT-3        | DC×27 9#  | 1 | 3 | — | 4   | 5.2 | 0.4-1.5 | 6500 | 5.5 | 33/35 | 470×360×475 |  |
| PC5200EXT-4        | DC×27 11# | 2 | 4 | 2 | 6   | 5.2 | 0.4-1.5 | 6500 | 5.5 | 33/35 | 470×360×475 |  |
| PC5200EXT-5        | DC×27 21# | 2 | 5 | 3 | 3×5 | 5.2 | 0.4-1.5 | 6500 | 5.5 | 33/35 | 470×360×475 |  |
| PC5200EXT-5H       | DC×27 21# | 2 | 5 | 3 | 5×5 | 5.2 | 0.4-1.5 | 6500 | 5.5 | 33/35 | 470×360×475 |  |



# PRECIOUS®

## PC5100D-EX 直驱筒式包缝机

Direct drive cylinder-bed super high-speed overlock sewing machine



筒式  
Cylinder-bed



直驱伺服马达  
Direct drive servo motor

### 用途:

适用于T恤衫、针织套衫的领口、袖口、腰部等嵌条的缝制。

### 特点:

- 1.具有圆筒形缝纫的小方头式，缝纫作业更容易。
- 2.小方头的圆周仅仅150mm，可轻松缝制。
- 3.落针处的右侧设计出10mm的空间，可安装各种装置。

### Application:

Applicable to T-shirts, knitted pullover collar, cuffs, waist and other piping sewing.

### Features:

- 1.Cylinder-bed with cylindrical sewing, it's easy for sewing.
- 2.Cylinder-bed circle only 150mm, can be easily sewn.
- 3.The right side of the needle have 10mm space, for installing a variety of devices.

| PC5100D-EX-3   | DC×27 9#  | 1 | 3 | — | 0.38-3.8 | 4 | 0.7-2 | 6000 | 5 | 33/35 | 470×360×475 |
|----------------|-----------|---|---|---|----------|---|-------|------|---|-------|-------------|
| PC5100D-EX-4   | DC×27 11# | 2 | 4 | 2 | 0.38-3.8 | 4 | 0.7-2 | 6000 | 5 | 33/35 | 470×360×475 |
| PC5100D-EX-4FR | DC×27 11# | 2 | 4 | 2 | 0.38-3.8 | 4 | 0.7-2 | 6000 | 5 | 33/35 | 470×360×475 |
| PC5100EX-3     | DC×27 9#  | 1 | 3 | — | 0.38-3.8 | 4 | 0.7-2 | 6000 | 5 | 33/35 | 470×360×475 |
| PC5100EX-4     | DC×27 11# | 2 | 4 | 2 | 0.38-3.8 | 4 | 0.7-2 | 6000 | 5 | 33/35 | 470×360×475 |



# PRECIOUS®

## PC5100D-EXT 直驱上下差动筒式包缝机

Direct drive top and bottom differential feed cylinder-bed super high-speed overlock sewing machine

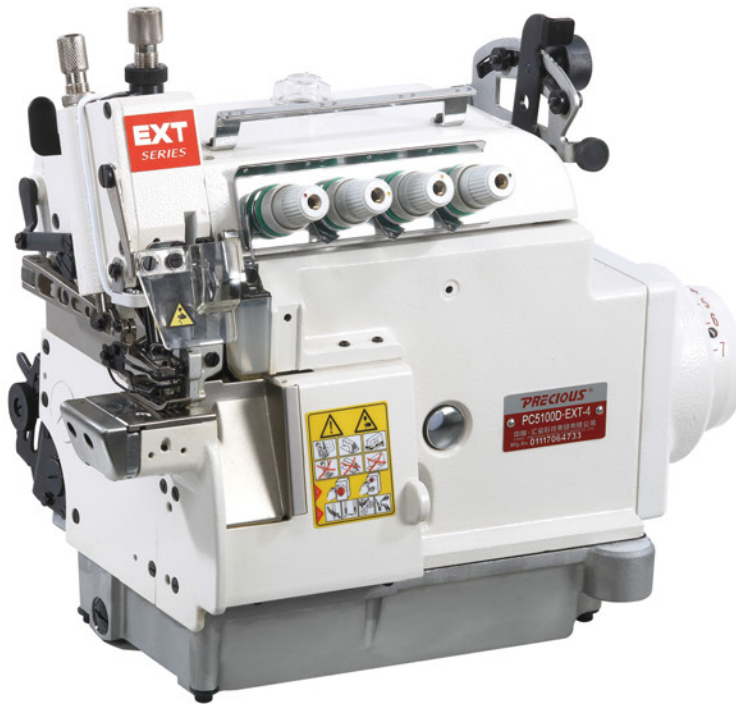

筒式  
Cylinder-bed



直驱伺服马达  
Direct drive servo motor

### 用途:

适用于T恤衫、针织套衫的领口、袖口、腰部等嵌条的缝制。

### 特点:

- 1.具有圆筒形缝纫的小方头式，缝纫作业更容易。
- 2.小方头的圆周仅仅150mm，可轻松缝制。
- 3.落针处的右侧设计出10mm的空间，可安装各种装置。
- 4.采用独立式送布机构，输送效率更高。
- 5.上送布牙有效送布距离变长，面料的直行性增加，线迹更完美。

### Application:

Applicable to T-shirts, knitted pullover collar, cuffs, waist and other piping sewing.

### Features:

- 1.Cylinder-bed with cylindrical sewing, it's easy for sewing.
- 2.Cylinder-bed circle only 150mm, can be easily sewn.
- 3.The right side of the needle have 10mm space, for installing a variety of devices.
- 4.Adopt independent feeding structure, more efficient.
- 5.Upper feed dog make the effective feeding distance longer, the straightness of the fabric increased, more perfect stitch.

| PC5100D-EX-3 | DC×27 9#  | 1 | 3 | — | 0.38-3.8 | 4 | 0.7-2 | 6500 | 5.5 | 33/35 | 470×360×475 |  |
|--------------|-----------|---|---|---|----------|---|-------|------|-----|-------|-------------|--|
| PC5100D-EX-4 | DC×27 11# | 2 | 4 | 2 | 0.38-3.8 | 6 | 0.7-2 | 6500 | 5.5 | 33/35 | 470×360×475 |  |
| PC5100EX-3   | DC×27 9#  | 1 | 3 | — | 0.38-3.8 | 4 | 0.7-2 | 6500 | 5.5 | 33/35 | 470×360×475 |  |
| PC5100EX-4   | DC×27 11# | 2 | 4 | 2 | 0.38-3.8 | 6 | 0.7-2 | 6500 | 5.5 | 33/35 | 470×360×475 |  |





# PRECIOUS®

## PC700D-3/4/5UT 直驱全自动包缝机 PC700-3/4/5 超高速包缝机

PC700D-3/4/5UT Direct drive full automatic overlock sewing machine  
PC700-3/4/5 Super high-speed overlock sewing machine



PC700D-3/4/5UT



PC700-3/4/5



直驱伺服马达  
Direct drive servo motor



自动剪线(可选配)  
Auto Trimmer (Optional)



### 用途:

适用于各种针织布、梭织布、男女服装、工作服等包边、包缝的缝制。

### 特点:

- 1.采用电脑直驱内置伺服马达,配置自动切线装置,并可自动定针。
- 2.采用HR硅油装置,即使使用耐热性较差的合成纤维也可用于高速缝纫作业,同时可降低机针温度,防止断线和布料的融化,使针脚稳定美观。据综合计算,生产效率可提高30%,比普通电机省电60%。

### Application:

Applicable to all kinds of knitted fabrics, woven fabrics, men and ladies' clothing, uniforms, overlock sewing.

### Features:

- 1.Adopt computer direct drive built-in servo motor,with automatic trimmer device, and automatic needle positioner.
- 2.Adopt HR silicone oiling mechanism,even use lower heat resistance synthetic fiber,also can use high-speed sewing and decline needle bar's temperature.avoiding thread breakage and clothing melting .It can improve the efficiency up to 30%,power saving up to 60%.

|                | DC×27 9#  | 1 | 3 | — | 0.5-3.8 | 4 | 0.7-1.7 | 5000 | 6   | 33/35 | 455×350×475 |
|----------------|-----------|---|---|---|---------|---|---------|------|-----|-------|-------------|
| PC700-3        | DC×27 9#  | 1 | 3 | — | 0.5-3.8 | 4 | 0.7-1.7 | 5000 | 6   | 33/35 | 455×350×475 |
| PC700-4-13H/KS | DC×27 9#  | 2 | 4 | 2 | 0.5-3.8 | 4 | 0.7-1.7 | 6500 | 6   | 33/35 | 455×350×475 |
| PC700-5-36     | DC×27 11# | 2 | 5 | 3 | 0.5-3.8 | 4 | 0.7-1.7 | 6500 | 5.5 | 33/35 | 455×350×475 |
| PC700-5-48     | DC×27 14# | 2 | 5 | 3 | 0.5-3.3 | 4 | 1-2.8   | 5500 | 5.5 | 33/35 | 455×350×475 |
| PC700-5-86     | DC×27 21# | 2 | 3 | 5 | 0.6-5.3 | 4 | 0.6-1.3 | 5500 | 5.5 | 33/35 | 455×350×475 |



# PRECIOUS®

**PC700-4-BK** 包线头倒回缝超高速包缝机  
**PC700-4-55A** 机械式松紧带超高速包缝机  
**PC700-4-CQ** 自动吸风切线装置高速包缝机

**PC700-4-BK** Super high-speed overlock sewing machine series for back stitching  
**PC700-4-55A** Robotistic elastic super high-speed overlock sewing machine  
**PC700-4-CQ** Overlock sewing machine with automatic air draft and thread trimmer device



**PC700-4-55A**  
机械式松紧带超高速包缝机  
Robotistic elastic overlock



**PC700-4-CQ**  
自动吸风切线装置高速包缝机  
Automatic air draft and thread trimmer

**PC700-4-BK**  
包线头倒回缝超高速包缝机  
Back stitching

**用途:**  
适用于各种针织布、梭织布、男女服装、工作服等包边、包缝的缝制。

- 特点:**
- 1.PC700-4-BK**  
该机型针板前方设有收空线环装置，可将空线环包入包缝线内，减少套结工序，并装有松机针线装置，在抬压脚时可同时松开两根机针线，适用于内裤、T恤衫等。
  - 2.PC700-4-55A**  
采用同步工分段变速松紧带传送装置，松紧带可同步送入，可将松紧带张力控制得均匀而准确，适用于泳衣、内裤、短裤等。
  - 3.PC700-4-CQ**  
空气吸入口垂直地设置于机针的横侧，利于空气吸力自动将空线环吸入后用切刀加以切断。

**Function:**  
Applicable to all kinds of knitted fabrics, woven fabrics, men and ladies' clothing, uniforms, overlock sewing.

- Features:**
- 1.PC700-4-BK**  
This machine has a free line loop device in the front needle board, it make free loop inside over lock seaming. Reduce bar tacking process and install the device of needle thread, it may loosen two needle thread in the same time when raising presser foot, it is suitable for underwear, T-shirts and so on.
  - 2.PC700-4-55A**  
It uses simultaneous sectional speed-variableband transmission device. Elastic belts can be transmitted simultaneously and tension of elastic belts can be controlled uniformly and exactly. It is applicable for swimsuits, underwear and pants.
  - 3.PC700-4-CQ**  
The air induction port vertical established by the horizontal side of the needle, by using air suction, can cut the thread coil automatically after absorbing it.

| PC700-4-181(BK)倒回缝 | DC×27 11# | 2 | 4 | 2 | 0.5-3.8 | 4 | 0.7-1.7 | 6500 | 5.5 | 33/35 | 455×350×475 |  |
|--------------------|-----------|---|---|---|---------|---|---------|------|-----|-------|-------------|--|
| PC700-4-55A        | DC×27 11# | 2 | 4 | 2 | 0.5-3.8 | 4 | 0.7-1.7 | 5000 | 6   | 33/35 | 455×350×475 |  |
| PC700-4-CQ         | DC×27 9#  | 2 | 4 | 2 | 0.5-3.8 | 4 | 0.7-1.7 | 6500 | 6   | 33/35 | 455×350×475 |  |



# PRECIOUS®

**PC700D-02 × 250 直驱双链滚边超高速包兜机**  
**PC700D-5-48 直驱打褶用超高速包缝机**  
**PC700D-6KH-CQ 直驱自动吸风切线装置三针六线超高速包缝机**

**PC700D-02 × 250 Direct drive high-speed double-chain cloth bound machine**  
**PC700D-5-48 Direct drive super high-speed overlock sewing machine for pleated sewing**  
**PC700D-6KH-CQ Direct drive 3-needle 6-thread super high-speed overlock sewing machine with automatic air draft and thread trimmer device**



PC700D-02 × 250



PC700D-5-48



PC700D-6KH-CQ

**用途:**  
适用于各种针织布、梭织布、男女服装、工作服等包边、包缝的缝制。

**特点:**  
**1.PC700D-5-48**  
打褶用五线包缝机附有褶紧（缩缝）装置，适用于童装裙子、女装、睡衣、床罩、窗帘打褶用的包缝机。适用于由薄到厚的便服女式上衣及衬裙用作业。

**2.PC700D-6KH-CQ**  
万能包缝机，可简单改变针和线的数量。其功能为：  
 1.单针三线包缝机（504、505）  
 2.双针四线包缝机（516+401）  
 3.双针五线包缝机（516）  
 4.三针六线包缝机（516+401）最适合服装店、小型服装厂、多品种小批量生产厂家，一机多用，为您节省资金。

**3.PC700D-02 x250**  
 1.适用于缝制大衣、夹克、西裤口袋内包缝辅助裤袋的包缝机。  
 2.将包边（捆带）卷成4折包入，使包边口完美顺畅，牢固不易松脱，即使是很小的弧形外缘都可以轻易完成包边作业。

**Function:** Applicable to all kinds of knitted fabrics, woven fabrics, men and ladies' clothing, uniforms, overlock sewing.

**Features:**  
**1.PC700D-5-48**  
5-yarn overlock sewing machine for pleating.It has ruching(seam shrinking) device,and it is applicable for pleating of children's clothes, shirts, women's garments, bedgowns, bedspreads, and curtains.

**2.PC700D-6KH-CQ**  
3-needle 6-thread overlock machine, called universal overlock machine. It can simply change needle and thread quantity.  
 Functions as follows:  
 1.Single needle and 3-thread Overlock sewing machine(504 and 505)  
 2.Double needle and 4-thread Overlock sewing machine(514)  
 3.Double needle and 5-thread Overlock sewing machine(516)  
 4.3-needle and 6-yarn cup seaming machine(516+401)  
 It is most applicable to garment shop, small garment factory, and manufacturers engaging in many-kind and small batch production, used for many purposes and saving your investment.

**3.PC700D-02 x250**  
PC700-02×250:Exclusively used for taping the edges of pocket bags in coats,jackets,trousers,etc.The tape binder can make the both sides of the tape rolling-in, which the edges of pocket bags with clean and smooth finishing (both top & bottom).



| PC700D-02×250 | DC×27 11# | 2 | 4 | 5   | 0.5-3.8 | 5 | 0.7-1.7 | 6000 | 3.5 | 33/35 | 455×350×475 |  |
|---------------|-----------|---|---|-----|---------|---|---------|------|-----|-------|-------------|--|
| PC700D-5-48   | DC×27 14# | 2 | 5 | 3   | 0.5-3.3 | 4 | 1-2.8   | 5500 | 5.5 | 33/35 | 455×350×475 |  |
| PC700D-6KH-CQ | DC×27 11# | 3 | 6 | 3x2 | 0.5-3.8 | 4 | 0.7-1.7 | 6000 | 5.5 | 33/35 | 455×350×475 |  |



# PRECIOUS®

## PC797D-3/4/5UT PC797-3/4/5

## 直驱全自动包缝机 超高速包缝机

PC797D-3/4/5UT  
PC797-3/4/5

Direct drive full automatic overlock sewing machine  
Super high-speed overlock sewing machine



PC797D-3/4/5UT



自动剪线(可选配)  
Auto Trimmer (Optional)



直驱伺服马达  
Direct drive servo motor



PC797-3/4/5

线迹图例



### 用途:

适用于各种针织布、梭织布、男女服装、工作服等包边、包缝的缝制。

### 特点:

- 1.整个机体进行全新优化设计,使整体外观更加优美,振动更小,噪音更低。
- 2.适用于各种薄料、中厚料、织物包边或包缝作业。由于采用自动润滑装置运转,顺畅自如。缝纫张力低,在高速下也能缝出稳定漂亮的线迹。

### Application:

Applicable to all kinds of knitted fabrics, woven fabrics, men and women clothing, uniforms, such as wrapping, overlock sewing.

### Features:

1. Whole machine be in progress of the newest optimized design, make overall appearance is more beautiful, less vibration, lower noise.
2. Applicable to the over edging operation of thin, medium and heavy fabrics. Due to its automatic lubricating device, the machine operates perfectly and smoothly at low sewing tension, also perfectly and stably stitches even at high speed.



| PC797-3-504M1-15        | DC×27 9#  | 1 | 3 | — | 3.6 | 1.5 | 0.7-2   | 6000 | 5.5 | 33/35 | 470×330×490 |  |
|-------------------------|-----------|---|---|---|-----|-----|---------|------|-----|-------|-------------|--|
| PC797-3-504M2-05        | DC×27 9#  | 1 | 3 | — | 3.6 | 4   | 0.7-2   | 6000 | 5.5 | 33/35 | 470×330×490 |  |
| PC797-3-504M5-04/BK     | DC×27 9#  | 1 | 3 | — | 3.6 | 4   | 0.7-2   | 6000 | 5.5 | 33/35 | 470×330×490 |  |
| PC797-3-504M2-04/LFC-2  | DC×27 11# | 1 | 3 | — | 3.6 | 4   | 0.7-2   | 5500 | 5.5 | 33/35 | 470×330×490 |  |
| PC797-4-514M2-24        | DC×27 11# | 2 | 4 | 2 | 3.6 | 4   | 0.7-2   | 6000 | 6   | 33/35 | 470×330×490 |  |
| PC797-4-514M2-24L/LFC-2 | DC×27 11# | 2 | 4 | 2 | 3.6 | 4   | 0.7-2   | 5500 | 5.5 | 33/35 | 470×330×490 |  |
| PC797-4-514M2-24L/LFC-2 | DC×27 11# | 2 | 4 | 2 | 3.6 | 3   | 0.7-2   | 6000 | 6   | 33/35 | 470×330×490 |  |
| PC797-5-516M2-35        | DC×27 14# | 2 | 5 | 3 | 3.6 | 5   | 0.7-2   | 5500 | 6   | 33/35 | 470×330×490 |  |
| PC797-5-516M2-55        | DC×27 14# | 2 | 5 | 5 | 3.6 | 5   | 0.7-2   | 5500 | 6   | 33/35 | 470×330×490 |  |
| PC797-5-516M2-57        | DC×27 18# | 2 | 5 | 5 | 5   | 6   | 0.7-1.4 | 5500 | 5.5 | 33/35 | 470×330×490 |  |



# PRECIOUS®

## PC747D 直驱超高速包缝机

### Direct drive super high-speed overlock sewing machine



直驱伺服马达  
Direct drive servo motor

**用途:**  
适用于各种针织布、梭织布、男女服装、工作服等包边、包缝的缝制。

**特点:**  
由于采用自动润滑装置运转，顺畅自如。缝纫张力低，在高速下也能缝出稳定漂亮的线迹。

**Application:**  
Applicable to all kinds of knitted fabrics, woven fabrics, men and women clothing, uniforms, such as wrapping, overlock sewing.

**Features:**  
As a result of automatic lubrication device operation, smooth and comfortable. Sewing tension is low, at high speed can also sew a stable stitch.

| PC737D  | DC×27 11# | 1 | 3 | — | 3.6 | 4 | 0.7-2 | 5500 | 5.5 | 33/35 | 470×330×490 |  |
|---------|-----------|---|---|---|-----|---|-------|------|-----|-------|-------------|--|
| PC747D  | DC×27 11# | 2 | 4 | 2 | 3.6 | 4 | 0.7-2 | 5500 | 5.5 | 33/36 | 470×330×490 |  |
| PC757D  | DC×27 11# | 2 | 5 | 2 | 3.6 | 5 | 0.7-2 | 5500 | 5.5 | 33/36 | 470×330×490 |  |
| PC757HD | DC×27 11# | 2 | 5 | 2 | 3.6 | 5 | 0.7-2 | 5500 | 5.5 | 33/37 | 470×330×490 |  |
| PC737   | DC×27 11# | 1 | 3 | — | 3.6 | 4 | 0.7-2 | 5500 | 5.5 | 33/35 | 470×330×490 |  |
| PC747   | DC×27 11# | 2 | 4 | 2 | 3.6 | 4 | 0.7-2 | 5500 | 5.5 | 33/36 | 470×330×490 |  |
| PC757   | DC×27 11# | 2 | 5 | 2 | 3.6 | 5 | 0.7-2 | 5500 | 5.5 | 33/36 | 470×330×490 |  |
| PC757H  | DC×27 11# | 2 | 5 | 2 | 3.6 | 5 | 0.7-2 | 5500 | 5.5 | 33/37 | 470×330×490 |  |



# PRECIOUS®

## PC737M 高速三线窄卷边包缝机 PC717M 鱼线机(细线机)

PC737M High-speed three-thread narrow bound machine  
PC717M Thin thread machine(fishing thread machine)



### 用途:

适用于童装、女装、大摆裙、婚纱、手帕、丝巾、工艺品、胸花装饰等制品的缝制。

### 特点:

- 1.采用自动卷边,使制品更加美观、牢固,有别于市面上的同类产品,包缝效果上佳,牢度特强。
- 2.线迹平直自然,适宜纱料、布料、高弹料。是高档童装、女装生产厂家理想的配套设备。
- 3.PC717M-A/B 0.2-0.3mm尼龙线(鱼线),尼龙线牢牢卷在布边内,缝后会自然弯曲,独特美观。

### Application:

Applicable for children's clothes, women's clothes, expansion skirt, wedding dress, handkerchiefs, scarves, handicrafts, brooch decoration and other products sewing.

### Features:

1. Adopt automatic crimping, make the products more beautiful and solid. It is different from other machines. The sewing effect is excellent and strong.
2. The stitch straight and natural. It is suitable for yarn, cloth and high elastic material. It is manufacturers ideal equipment which make high-grade children's cloth, women's cloth.
3. PC717M-A/B 0.2-0.3mm nylon line (fishing line), nylon thread firmly rolled in the cloth edge. The seam will naturally bend, unique and beautiful.

|          |          |   |   |   |       |       |       |      |     | kg    | mm          |  |
|----------|----------|---|---|---|-------|-------|-------|------|-----|-------|-------------|--|
| PC737M-A | DC×27 9# | 1 | 3 | — | 0.5-3 | 1.5-3 | 0.7-2 | 6000 | 5.5 | 33/35 | 470×330×480 |  |
| PC737M-B | DC×27 9# | 1 | 3 | — | 0.5-3 | 1.5-3 | 0.7-2 | 6000 | 5.5 | 33/35 | 470×330×480 |  |
| PC717M-A | DC×27 9# | 1 | 3 | — | 0.5-3 | 1.5-3 | 0.7-2 | 6000 | 5.5 | 33/35 | 470×330×480 |  |
| PC717M-B | DC×27 9# | 1 | 3 | — | 0.5-3 | 1.5-3 | 0.7-2 | 6000 | 5.5 | 33/35 | 470×330×480 |  |



# PRECIOUS®

## F20 智能一体超高速绷缝机

Smart mechanical & electrical integrated super high speed interlock sewing machine



### 用途:

适用于针织内衣、运动衣裤、T恤衫等针织品、休闲服的车缝。

### 特点:

- 1.时尚一体化设计，具有良好的操作性、节能性。
- 2.加大移动式打线凸轮，方便穿线，防止底线缠绕。
- 3.自动剪线、拨线，自动抬压脚等功能，操作简便，提高效率。
- 4.语音导航，简单易学。
- 5.一键复原和USB智能端口，高效省力。

### Application:

Suitable for knitted underwear, sportswear, T-shirts and other knitwear, casual clothes sewing.

### Features:

- 1.Fashion integration design, with good operation and energy-saving.
- 2.Increase the threading cam, easy threading, to prevent the bottom line winding.
- 3.Automatic thread trimming, thread wiper, automatic feet lifting these make it easy to operate, improve efficiency.
- 4.Voice navigation, easy to learn.
- 5.A key recovery and USB smart port, efficient and labor-saving.



## F20 产品优势

### Advantage



自动剪线  
Auto thread trimmer



自动抬压脚  
Auto presser foot lifter



自动拔线  
Auto thread wiper



外置打线凸轮  
External threading cam

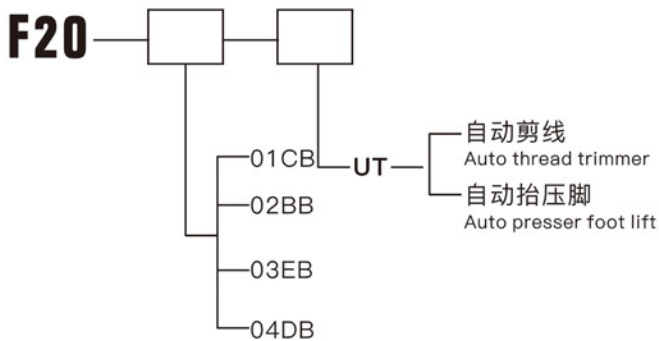

|   |   |
|---|---|
| <br><b>F20-01CB</b><br>基本型<br>BASIC MODEL | <br><b>F20-02BB</b><br>缝滚条<br>SEWING ROLLED-EDGE                           |
| <br><b>F20-03EB</b><br>盖缝<br>COVER SEAM   | <br><b>F20-04DB</b><br>四针六线基本型<br>FOUR-NEEDLE<br>SIX-THREAD<br>BASIC MODEL |



F20-01UT



9-14#



3



5



5.6/6.4



4.4



0.65~1.3



5000



5



45/50



615×405×655





# PRECIOUS®

## PC31016D-01CB/UT(W500) 直驱自动剪线超高速绷缝机

### Direct drive super high-speed interlock sewing machine with auto trimmer



**PC31016D-01CB/UT(W500)**  
直驱自动剪线超高速绷缝机



**PC31016-01CB/UT-FQ**  
自动切线多功能(三合一)绷缝机



PC31016-01CB  
基本型  
BASIC MODEL



PC31016-02BB  
缝滚条  
SEWING ROLLED-EDGE



PC31016-03EB  
盖缝  
COVER SEAM



PC31016-04DB  
四针六线基本型  
FOUR-NEEDLE  
SIX-THREAD  
BASIC MODEL



PC31016-05MD  
花边松紧带  
ELASTIC LACE CORD



PC31016-06AS  
双钩针环缝  
DOUBLE CHAIN-STITCH  
IN TWO-LOOPER



PC31016-07/F  
裤耳车缝  
TROUSER TAPE SEAM



PC31016-08AB  
下摆折边缝  
BOTTOM FOLDING SEAM

#### 用途:

适用于针织品、运动衫、休闲服等的缝制。

#### 特点:

1. 本机型是高速平台式绷缝机之基本机种，可加装多种附件以适用于不同的作业。
2. 新式针杆回油系统，绝无漏油疑虑。
3. 完备的自动供油系统与滤油装置，确保最高缝速可达6000针/分钟。

注：PC31016D-01CB/UT-FQ具有自动剪线，自动抬压脚，集一般车缝、滚条缝、盖缝于一体的多功能（三合一）绷缝机。

#### Application:

For knitwear, sport clothes, casual clothes and other sewing.

#### Features:

1. This model is the basic model of high-speed platform-type sewing machine, can be installed a variety of accessories to apply to different operations.
2. New needle bar oil return system, no oil suspected.
3. Complete automatic oil supply system and oil filter device to ensure that the maximum sewing speed up to 6,000 / min.

**Note:** PC31016D-01CB / UT-FQ with automatic trimming, automatic presser lifter, set the general sewing, tape binding, cover seaming in one of the multi-functional (three-in-one) interlock sewing machine.

|                     |     |     |     |                      |         |       |       |      |     |   |       | kg          | mm |
|---------------------|-----|-----|-----|----------------------|---------|-------|-------|------|-----|---|-------|-------------|----|
| PC31016D-01CB/UT    | 11# | 2/3 | 4/5 | 3.2/4.0/4.8/5.6⊙/6.4 | 1.2-4.4 | 1:0.5 | 1:1.3 | 5000 | 6.3 | ★ | 45/50 | 615×405×655 |    |
| PC31016D-01CB/UT-FQ | 11# | 2/3 | 4/5 | 3.2/4.0/4.8/5.6⊙/6.4 | 1.2-4.4 | 1:0.5 | 1:1.3 | 5000 | 6.3 | ★ | 45/50 | 615×405×655 |    |
| PC31016-01CB        | 11# | 2/3 | 4/5 | 3.2/4.0/4.8/5.6⊙/6.4 | 1.2-4.4 | 1:0.5 | 1:1.3 | 5000 | 6.3 | — | 45/50 | 615×405×655 |    |
| PC31016-02BB        | 11# | 2/3 | 4/5 | 3.2/4.0/4.8/5.6⊙/6.4 | 1.2-4.4 | 1:0.5 | 1:1.3 | 5000 | 6.3 | — | 45/50 | 615×405×655 |    |
| PC31016-03EB        | 11# | 2/3 | 4/5 | 3.2/4.0/4.8/5.6⊙/6.4 | 1.2-4.4 | 1:0.5 | 1:1.3 | 5000 | 6.3 | — | 45/50 | 615×405×655 |    |
| PC31016-04DB        | 11# | 4   | 6   | 5.6⊙/6.4             | 1.2-4.4 | 1:0.5 | 1:1.3 | 5000 | 6.3 | — | 45/50 | 615×405×655 |    |
| PC31016-05MD        | 11# | 2/3 | 4/5 | 3.2/4.0/4.8/5.6⊙/6.4 | 1.2-4.4 | 1:0.5 | 1:1.3 | 5000 | 6.3 | — | 45/50 | 615×405×655 |    |
| PC31016-06AS        | 11# | 2   | 4   | 5.6⊙/6.4             | 1.2-4.4 | 1:0.5 | 1:1.3 | 5000 | 6.3 | — | 45/50 | 615×405×655 |    |
| PC31016-07/F        | 11# | 2   | 3   | 5.6⊙/6.4             | 1.2-4.4 | 1:0.5 | 1:1.3 | 5000 | 6.3 | — | 45/50 | 615×405×655 |    |
| PC31016-08AB        | 11# | 2/3 | 4/5 | 3.2/4.0/4.8/5.6⊙/6.4 | 1.2-4.4 | 1:0.5 | 1:1.3 | 5000 | 6.3 | — | 45/50 | 615×405×655 |    |



# PRECIOUS®

## PC31026D-01/UT 直驱自动剪线超高速小方头式绷缝机

## PC31026D-35ZD/UT/CQ 直驱自动剪线带左切刀超高速绷缝机

Direct drive super high-speed cylinder-bed interlock sewing machine with auto trimmer  
 Direct drive super high-speed interlock sewing machine with left cutter



PC31026D-01/UT



PC31026D-35ZD/UT/CQ

### PC31026D-01/UT 用途:

- 1.一般车缝。
- 2.一般针织品, 运动衫、休闲服等。

### 特点:

- 1.本机型是高速小方头式绷缝机之基本机种, 可加装多种附件以适用不同之作业。
- 2.新式针杆回油系统, 绝无漏油疑虑。
- 3.针杆传动机构, 采用密封式的设计, 更安全与更易保持清洁。
- 4.机体周长只有280mm, 适用于领口及袖口等较小部位。

### PC31026D-35ZD/UT/CQ 用途:

针织T恤、休闲服、运动服的下摆或短袖袖口的车缝作业。

### 特点:

- 1.具有车下摆导模, 左切刀修布装置及吸屑导管, 可轻易将环状裁片向下卷折, 并由左切刀将卷折后之裁片在下层的部分的左边缘修齐, 再进行车缝, 而在切刀修布的同时, 布屑则由吸风装置或空气压机经吸屑导管吸出。
- 2.具有修剪缝合布边的左切刀装置。由左切刀将卷折后裁片在下层的部分的左边修齐, 使布料平行整齐, 再进行车缝, 形成美丽的成品。
- 3.新式针杆回油系统, 绝无漏油疑虑。
- 4.针杆传动机构, 采用密封式的设计, 更安全与更易保持清洁。
- 5.机体周长只有280mm, 适用于领口及袖口等较小部位。

### PC31026D-01/UT Application:

- 1.General sewing.
- 2.General knitwear, sports clothes, casual clothes and so on.

### Features:

- 1.This model is a high-speed cylinder bed sewing machine of the basic models, it can be installed with a variety of accessories to apply to different operations.
- 2.New needle bar oil return system, no oil suspected.
- 3.Needle bar drive mechanism, adopt sealed design, more secure and easier to keep clean.
- 4.Body circumference is only 280mm, suitable for the collar and cuffs and other smaller parts.

### PC31026D-35ZD/UT/CQ Application:

Suitable for Knit T-shirt, casual clothes, sportswear hem or short-sleeved cuffs sewing operations.

### Features:

- 1.With the sewing machine under the wobble guide, the left knife repair cloth device and the vacuum pipe, you can easily bend the round piece down, and then the left knife will bend the pieces in the lower part of the left edge of the repair, and then For sewing, in the cutter cloth at the same time, the cloth by the suction device or air compressor suction through the suction pipe.
- 2.A left knife device with a trimming suture. By the left knife will be folded after the pieces in the lower part of the left part of the repair, so that the fabric parallel to the tidy, and then sewing, the formation of beautiful products.
- 3.New needle bar oil return system, no oil suspected.
- 4.Needle bar drive mechanism, adopt sealed design, safer and easier to keep clean.
- 5.Body circumference is only 280mm, suitable for the collar and cuffs and other smaller parts.



PC31026D-01/UT

9-14#

2/3

4/5

3.2/4.0/4.8/5.6/6.4/  
4.8/5.6/6.4

0.9-4.5

0.6~1.3

5000

5

★

45/50

615×405×655

PC31026D-35ZD/UT/CQ

11#

2/3

4/5

3.2/4.0/4.8/5.6○/6.4

1.2-4.4

1:0.5 1:1.3

5000

5

★

45/50

615×405×655



# PRECIOUS®

## PC008-04/08/13/17/23 多针半筒型双链式环缝机(自由针位)

### Multi-needle half-cylinder double-chain ring needle lockstitch (free gauge set)



PC008-04064P

可选择的辅助件:

VCE:橡胶导片装置

RL:环形裤腰撑开轮

VWL:松紧带前送装置, 可调整松紧量

FH: 下固定式送带盘装置

VAD:气动式抬压脚装置

Accessories choice:

VCE rubber slice-leading device

RL loop trouse waist support sheel

VWL front elastic feeding device,it easy to operate and the elasticity can be adjusted

FH:below-table tape feeding holder

VAD:pneumatic lift-press feet device

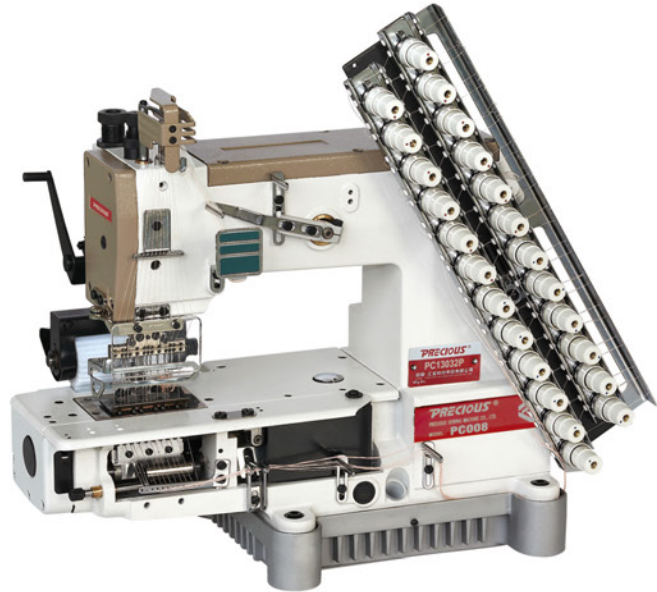

PC008-13032P

#### 用途:

适用于各种服装的裤头松紧带、贴条带、衬衫门襟、车缝衬衫折布、橡筋褶皱等缝制。

#### 特点:

- 1.采用拔杆拨线机构, 形成线环。
- 2.半筒型设计, 方便缝制环形衣物。
- 3.具有多种针间距, 在15~36mm范围内最多可安装33根机针。
- 4.弹出式弯针机构方便用户穿线。

#### Application:

Applicable to all kinds of trousers elastic band, sticker, shirt placket, sewing shirt folding cloth, rubber wrinkles and other sewing.

#### Features:

- 1.The driving rod thread wipe instruct, become thread ring.
2. Half cylinder bed design, easy to sew round clothing.
3. With variety of needle gauge, it can be installed up to 33 needle within 15 to 36mm.
- 4.The pop-up loop mechanism is easy for users to thread.

| PC008-04 | 11#~14# | 4  | 8  | 1/8" 1/4"  | 1.4~3.6 | 12 | 4000 | 47/50 | 630×260×630 |
|----------|---------|----|----|------------|---------|----|------|-------|-------------|
| PC008-08 | 11#~14# | 8  | 16 | 3/16" 1/4" | 1.4~3.6 | 12 | 4000 | 47/50 | 630×260×630 |
| PC008-13 | 11#~14# | 13 | 24 | 1/8"       | 1.4~3.6 | 12 | 4000 | 47/50 | 630×260×630 |
| PC008-17 | 11#~14# | 17 | 24 | 1/8"       | 1.4~3.6 | 12 | 4000 | 47/50 | 630×260×630 |
| PC008-23 | 11#~14# | 23 | 24 | 1/8"       | 1.4~3.6 | 12 | 4000 | 47/50 | 630×260×630 |



**PRECIOUS®**

# PC008-12064VPQ 伸缩橡筋车缝机

PC008-12064VPQ Flex elastic sewing machine

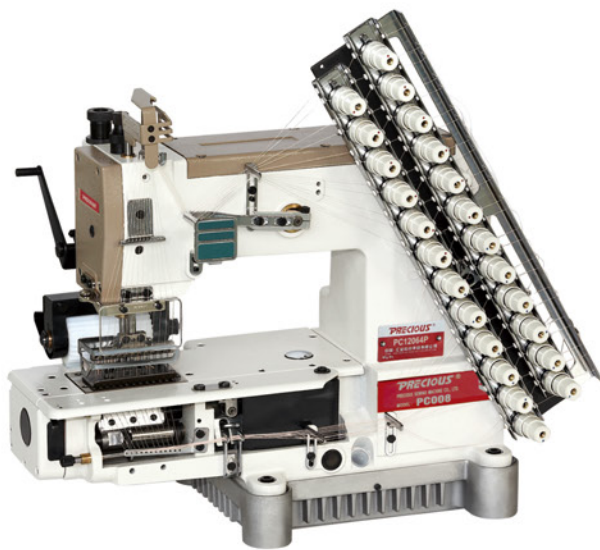

PC008-12064P



PC008-12064VPQ



**用途:**  
适用于一般橡筋线的缝制。

**特点:**  
1.采用拔杆拔线机构，形成线环。  
2.半筒型设计，方便缝制环形衣物。  
3.弹出式弯针机构方便用户穿线。

**Application:**  
Applicable to the flex elastic.

**Features:**  
1.The driving rod thread wipe instruct, become thread ring.  
2.Half cylinder bed design, easy to sew round clothing.  
3.The pop-up loop mechanism is easy for users to thread.

|                 |          |    |    |      |         | mm |      | kg    | mm          |
|-----------------|----------|----|----|------|---------|----|------|-------|-------------|
| PC008-12064P    | DV57 16# | 12 | 24 | 1/4" | 1.4~3.6 | 12 | 1500 | 48/52 | 600×400×600 |
| PC008-12064/VPQ | DV57 16# | 12 | 12 | 1/4" | 1.4~3.6 | 12 | 1500 | 48/52 | 600×400×600 |



# PRECIOUS®

## PC1302 平台型双重环缝曲牙机

Flat-bed double chain stitch fagotting zigzag machine











**用途:**  
适合女装、童装、手帕、桌布、围巾、手套等附加产品的装饰缝。

**特点:**  
能缝4点外曲牙，分单针、双针不同要求。

**Application:**  
Applicable to lady swear, children's wear, handkerchiefs, table cloth, shawl, gloves etc.

**Features:**  
It can sew 4 points, one needle and 2 needles.

|  |  |  |  |  |  |  |  |  |  |
|---|---|---|---|---|---|--|---|---|---|
| PC1302-4W   | UOX163 11#  | 2   | 3   | 0.8~1.5   | —   | 8  | 3000  | 41/45   | 620×405×590   |
| PC1302-5W   | UOX163 11#  | 2   | 3   | 0.8~1.5   | —   | 8  | 3000  | 41/45   | 620×405×590   |



# PRECIOUS®

## PC1508P 1-4针平台型弯针横向双重环缝链式裤腰缝纫机

## PC1404P 四针平台型勾针纵向双重环缝式缝纫机

**PC1508P 1-4 needle flat-bed double-chain stitch machine with horizontal looper movement mechanism**  
**PC1404P 4- needle flat-bed double - chain stitch sewing machine**



**PC1508PR-D**



**PC1404P**

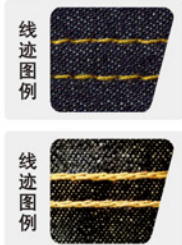

### PC1508PR/PC1508PR-D

**用途:**  
适用于中厚料到厚料使用, 牛仔的卷边缝、上腰、上松紧等车缝。  
**特点:**  
后拖轮保证高速运转时送布均衡, 线迹美观。后拖轮的下轮左右分开, 便于转弯缝(4针)。

### PC1508P

**用途:**  
适用于中厚料到厚料使用, 牛仔的卷边缝、上腰、上松紧等车缝。  
**特点:**  
后拖轮保证高速运转时送布均衡, 线迹美观。

### PC1404P

**用途:**  
适用于内衣、运动服、女装、工作服、室内装饰品等。  
**特点:**  
上松紧、门襟滚条、上腰、装饰缝等。

### 附加装置:

MR:打缆装置 WB:上腰装置  
PSF:门襟装置 PSM:装饰装置  
PSSM:打缆和装饰装置  
PL:滚条装置 ET:下线为松紧线专用  
MD-1:前松紧带送布条调整装置

### PC1508PR/PC1508PR-D

**Application:**  
Applicable to medium and heavy material, hem seam of jeans, on the waist, on the elastic band and other sewing.

### Features:

The rear puller ensure high-speed operation, send cloth balanced, beautiful stitch. The bottom puller of rear puller left and right separate, it is easy to bend seam(4 needle).

### PC1508P

**Application:**  
Applicable to medium and heavy material, hem seam of jeans, on the waist, on the elastic band and other sewing.

### Features:

The rear puller ensure high-speed operation, send cloth balanced, beautiful stitch.

### PC1404P

**Application:**  
Applicable to under wear sportswear, lady's clothes, interior decorated goods.

### Features:

Attaching elastic. sewing the front of shirts, on the waist, on the elastic band and so on.

### Option:

MR:machine with quilting device WB:machine for attaching waistbands  
PSF:machine for shirt fronting PSM:machine for smocking  
PSSM:machine for simultaneous shirring+smocking  
PL:Machine for attaching line tapes ET:looper thread elastic model  
MD-1: metering device

|          |               |   |   |             |         | mm |      | kg    | mm          |
|----------|---------------|---|---|-------------|---------|----|------|-------|-------------|
| PC1508PR | Tvx5<br>21#   | 4 | 8 | 1/4-3/4-1/4 | 1.8~4.5 | 10 | 4500 | 41/45 | 620×405×590 |
| PC1508P  | Tvx5<br>21#   | 4 | 8 | 1/4-1,-1/4  | 1.8~4.5 | 10 | 4500 | 41/45 | 620×405×590 |
| PC1404P  | UOX113<br>14# | 4 | 8 | 1/4-1,1-1/4 | 1.8~4.3 | 10 | 4000 | 41/45 | 620×405×590 |



# PRECIOUS®

## PC313-90/105 全自动智能模板机

Fully automatic intelligent templates machine



**用途:**

适用于各种羽绒服、服装等模块化的缝制。

**特点:**

- 1.全新的自动化缝制模式。
- 2.三大优势：操作简单、品质保证、高效生产。
- 3.采用最新的导轨运行模式，转变更高，速度更快。

**Application:**

Applicable to all kinds of down jackets, clothing and other pattern sewing.

**Features:**

- 1.Brand new automatic sewing mode.
- 2.Three advantages: simple operation, quality assurance and efficient production.
- 3.Adopt the latest guide rail operation mode to make change and speed faster.

**主要技术参数:**

**Parameters:**

针距: 0.5-6mm  
Stitch: 0.5-6mm

缝纫速度: 200rpm~3000rpm (针距2.5mm时普通线料)  
Sewing speed: 200rpm~3000rpm (2.5mm stitch)

可同时识别模板个数: 1-31; 1-250;  
Templates can also identify the number: 1-31; 1-250;

缝针: DP×17 11# (#8-#24)、DP×5 (#7-#24) DB×1 #6-#24  
Sewing needle: DP×17 (#8-#24)、DP×5 (#7-#24)、DB×1 (#6-#24)

程序输入装置: 电脑USB数据线或U盘  
Program input device: PC USB data cable or U disk

适用缝制范围: X轴向: 1000-1300mm可定制更长; Y轴向: 480-800mm  
Applicable to Sewing range: X axis1000-1300mm, can be extend to customers' request; Y axial: 480-800mm

程序记忆载体: EPROM内存  
Program Memory Carrier: EPROM memory

记忆程序数量: 最多999种  
Program memory: Up to 999kinds

缝纫机马达: 750W直接驱动伺服马达  
Sewing machine motor: 750W direct drive servo motor

总重量: 490kg 电源规格: 220V 1200W  
Total weight: 280/350kg Power supply: 220V 1200W

使用空气规格: 0.25-0.4MPa (最大0.5MPa)  
Using air Specifications: 0.25-0.4MPa (Max 0.5MPa)



# PRECIOUS®

## PC982 高速电脑圆头锁眼机

### Computer controlled high-speed round button holing machine

**用途:**

用于男装、女装、劳动布、工作服的锁眼作业。

**特点:**

1. 电脑控制程序，触摸屏控制扣眼形状。
2. 可方便选择先切刀和后切刀。
3. 循环缝制，生产计数，自己诊断功能。

**Application:**

Applicable to suit-dress, men's clothing, denim, button holing.

**Features:**

1. Computer control program, touch screen control button hole shape.
2. Easy to choose the beginning cutter and ending cutter.
3. Cycle sewing, production output, self-diagnosis function.

## 技术参数 Technical parameter

|                                      |   |
|--------------------------------------|---|
| 缝制速度/speed                           | 1000~2500rpm  |
| 针迹形状/shape of stitch                 | no bar taking, cone bar taking, straight bar taking, round bar taking, chrysanthemum bar taking |
| 锁缝长度/length                          | 5~50mm, 5~42mm  |
| 针迹节距/stitch length                   | 0.5~2.0mm   |
| 针迹幅宽/width                           | 1.5mm~5.0mm (mechanical maximum 4.0mm, procedural maximum 1.0mm)                                |
| 锥形加固长度/conical reinforcement length  | 0~20mm  |
| 压脚高度/height of presser foot          | standard 12mm (maximum 16mm)  |
| 启动方式/start mode                      | foot switch (foot switch, with pedal type) or hand switch                                       |
| 送布方式/feed mode                       | X.Y.O three pulse motor feed  |
| 安全装置/safety device                   | auto stopped device which power has problem   |
| 上轴马达/upper axle motor                | AC servo motor (4 phase, 550w)  |
| 空气压力主调节器/air pressure main regulator | 0.5mpa  |
| 电源/power                             | 220v 50hz   |
| 重量/weight                            | head 120kg, control panel 0.6kg, control box 14.2~16.2kg  |

|    | 圆头扣眼<br>round button hole | 平头扣眼<br>straight button hole | 圆头扣眼带流线加固缝的<br>round button hole with streamline bar tacking | 平头扣眼带流线加固缝的<br>straight button hole with streamline bar tacking | 圆头扣眼带平头加固缝的<br>round button hole with flat bar tacking | 平头扣眼带平头加固缝的<br>straight button hole with flat bar tacking |
|----|---------------------------|------------------------------|--|---|--|---|
| 00 |                           |                              |  |   |  |   |
| 01 |                           |                              |  |   |  |   |
| 02 |                           |                              |  |   |  |   |





**PRECIOUS®**

# PC1790N 自动高速门襟锁眼机

High-speed automatic pants placket lockstitch button holing machine



**用途:**

用于薄中厚料、牛仔布、哔叽布、弹力布的锁眼作业。

**特点:**

- 1.在缝制过程中, 准备下一片面料的功能。
- 2.自动锁眼缝纫机连续的进行锁眼工作, 操作工在工作中会发生等待时间的预留装置, 能在锁眼缝制中准备下一片身片, 有效的活用等待时间, 实现高生产性。

**Application:**

Suitable for holing attaching to light,medium,heavy duty ,jeans, serge and elastic fabric.

**Features:**

- 1.In the sewing process,machine have the function ready for the next piece of fabric.
- 2.Auto button holing sewing machine working continuously button holing work,the operator in the work will be happen in the wait time ofdevice.The machine will be ready for the next piece of fabric in the button holing sewing ,effective use of waiting time,to acheieve high production.

## 技术参数 Technical parameter

|                                     |   |
|-------------------------------------|---|
| 搭载头部/head                           | PC1790(专用头部) PC1790(dedicated head)             |
| 最快缝制速度/maxmium speed                | 4200sti/min(normal 3600sti/min)                 |
| 缝制尺寸/sewing size                    | standard 4mm*25mm(component exchange 6mm*120mm) |
| 切布长度/length of fabric               | 6.4~19.1mm(1/4~3/4inch)                         |
| 压脚抬升量/height of presser foot        | maxmium 14mm                                    |
| 使用针/needle                          | dp*5#11J~#14J(standard#11J)                     |
| 送布方式/feed mode                      | pulse motor                                     |
| 送布方向/feed direction                 | right(for men),left(for women)                  |
| 送布单位/feed unit                      | 0.1mm   |
| 记忆花样数/rememered samples             | 20  |
| 锁眼个数/numbers of holes               | 1-20  |
| 电源/power                            | 220v  |
| 消费电力/consumer power                 | 1000va  |
| 空压机气量、消费量/air compressor air volume | 0.5mpa(5kg/cm2)240/min                          |
| 机器尺寸/size                           | 1910*850*920                                    |
| 预调装置/preconditioning device         | standard  |
| 身片储存器/body store                    | standard  |
| 身片整理装置/body make device             | yes   |



# PRECIOUS®

## PC1790 高速电脑平头锁眼机

Computer controlled high-speed lockstitch straight button holing machine



线迹  
Stitch

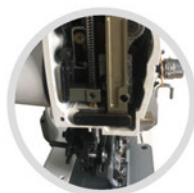

头部微油  
Mini oil



电子夹线  
Electronic thread tension



伺服电机  
Servo motor



电机切线  
Motor trimmer

### 用途:

运用于各种针织、棉纺、化纤等织物的纽孔加工，更适用于袖子的锁眼作业。

### 特点:

- 1.由电子控制摆针、送布、抬压脚及切线的平头锁眼机。
- 2.独特的电子夹线机构，能在缝制开始和结束时设定完上线张力。
- 3.采用5个高转速的步进马达（上剪线、下剪线、送料、摆针、抬压脚）使线迹稳定美观。
- 4.干机头化技术，消除了缝制品污染。

### Application:

Suitable for knitting wear, cotton fabrics, fibers and sleeve button holing sewing.

### Features:

1. Electronic control pendulum needle, feed the cloth, foot lifter and trimmer straight button hole machine.
2. Unique electronic clamping mechanism, can be set at the beginning and end of sewing set on-line tension.
3. With five high-speed stepper motor (upper trimmer, bottom trimmer, feeding, pendulum, auto presser foot lifter) to make the stitch stable and beautiful.
4. Dry head of the technology, avoid the products being polluted.



PC1790



DPX5  
#11J-#14J



1/4" -1" -1/4"  
6.4-19



25



2.5-5



17



★



4200



1000W



112/120



550×500×480



# PRECIOUS®

## PC781D/PC781 高速直驱平头锁眼机

### High speed direct drive button holing sewing machine



PC781D



PC781



线迹图例



切刀部位  
Cutter



直驱电机  
Direct drive motor

**用途:**  
用于针织、棉纺、化纤织物锁眼作业。

**特点:**  
PC781D:  
自动上针位、自动剪线、纽孔长度、宽度及针数可调、自动润滑。  
PC781:  
1.可缝制平线迹与三角线迹, 纽孔长度、宽度及针数可调。  
2.具备自动润滑系统及自动剪线装置。

**Application:**  
Applicable to knitting wear,cotton fabrics, fibers button holing sewing.

**Features:**  
PC781D  
Automatic needle positioner, Automatic Trimmer, Adjustable length, width and stitch count of button hole, Automatic oil lubrication.  
PC781  
1. Sewing for straight stitch and triangle stitch.  
2. Automatic oil lubrication and automatic trimmer.

| PC781D | DP×5<br>11#-14# | 2 | 1/4" - 1' 1/4"<br>6.4-31.7 | 40 | 2.5-5 | 6.4,9.5,12.7,<br>19,25.4,31.7<br>1/4", 3/8", 1/2",<br>3/4", 1", 1 1/4" | 190(标准)<br>standard<br>83,88,100,110,<br>123,152,170,<br>190,212,225 | 12<br>(15/32") | 3600 | ★ | AC550W                          | 63.5/70 | 695×345×830 |
|--------|-----------------|---|----------------------------|----|-------|--|--|----------------|------|---|---------------------------------|---------|-------------|
| PC781  | DP×5<br>11#-14# | 2 | 1/4" - 3/4"<br>6.4-19      | 22 | 2.5-4 | 6.4,9.5,<br>12.7,19<br>1/4", 3/8",<br>1/2", 5/32"                      | 123(标准)<br>standard<br>83,100,110,<br>123,152,170,<br>190,225        | 12<br>(15/32") | 3600 | — | 370w<br>1400r.p.m.<br>220v/380v | 63.5/70 | 695×345×830 |



# PRECIOUS®

## PC1900A 高速电子套结机

### High-speed Electronic Bartacking Sewing Machine



- PC1900A
- S:标准  
Standard specification
  - H:厚料  
Heavy duty
  - F:内衣  
Underwear
  - M:针织  
Knitting
  - W:大旋梭  
Large hook



PC1904AS

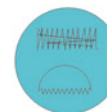

PC1900AS



#### 用途:

用于各种口袋及商标无纺布、手提袋、西服、牛仔服的套结加固缝作业。

#### 特点:

1. 具备纵30mm\*横40mm的缝制范围, 可对应多样化的花样缝制。
2. 在原基础上增加半月形、圆形、菊花孔锁服等50多个种类花样。
3. 可全新升级的花样输入模式, 通过U盘下载所需花样, 直接插入操作盒上的USB端口, 即可完成花样输入。
4. 在机头处设置手轮, 方便落针点的确认。

#### Application:

Applicable to kinds of pocket and trademark, nonwoven, handbag, suit, jeans bartacking and reverse seaming.

#### Features:

1. The sewing range is width 30mm\*length 40mm, can sew variety of sewing patterns.
2. On the basis of the original, it increases about 50 patterns such as half moon, round, chrysanthemum hole etc.
3. Brand new upgrade pattern input mode, through the U disk to download the required pattern, directly into the operation of the USB port on the box, you can complete the pattern input.
4. Add a hand wheel in the head to confirm the needle position easily.

| PC1900A | DPX5<br>14# | 0.1-10 | 13 | 3000 | ★ | 45/52 | 800×450×820 |
|---------|-------------|--------|----|------|---|-------|-------------|
| PC1904A | DPX5<br>14# | 0.1-10 | 13 | 3000 | ★ | 45/52 | 800×450×820 |



# PRECIOUS®

## PC1903AS 高速电子钉扣机

High-speed electronic button attaching sewing machine



**用途:**

适用于各种西服、牛仔服等中厚料的钉扣。

**特点:**

1. 自动夹线。
2. 可在操作盘上设定各种缝制材料的面线张力。
3. 采用先进的干线头化技术，面部实现了无机油化自动夹线。

**Application:**

Attaching buttons for medium fabric such as suit and jeans.

**Features:**

1. Automatic thread tension.
2. The up thread tension of various sewing material can be set on the operating panel.
3. Adopt advanced wireheading technology, achieve no-oil automatic thread tension in the front of machine.

|          |                 |   |         |   |    |      |   | kg    | mm          |
|----------|-----------------|---|---------|---|----|------|---|-------|-------------|
| PC1903AN | DPX5<br>14#-16# | 1 | 0.1-1.0 | ★ | 14 | 3000 | ★ | 45/52 | 800×405×820 |
| PC1903AS | DPX5<br>14#-16# | 1 | 0.1-1.0 | ★ | 14 | 3000 | ★ | 45/52 | 800×405×820 |



# PRECIOUS®

## PC1377D 直驱钉扣机 PC373 钉扣机

PC1377D Direct drive button attaching machine  
PC373 Button attaching sewing machine



PC1377D

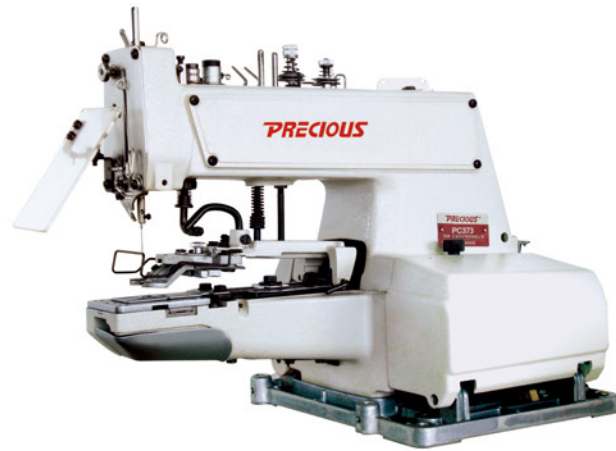

PC373



### PC1377D 用途:

适用于衬衫、西服衣裤、外套工作服等双孔、四孔或立式纽扣的缝制。

### 特点:

1. 三种线迹。可通过简单操作实现线迹“=”与“X”及“+”的转换。
2. 从4孔到2孔之间的转换。
3. 可选配加装电动送扣装置。

### PC373 用途:

缝制在衬衫、西服衣裤、外套工作服上的二孔或四孔平纽扣。

### 特点:

- PC373D
1. 主要用于二孔或四孔的平纽扣缝制。
  2. 从四孔到二孔钉扣形式的变更。
  3. 可加装电动送扣装置。
- PC373
1. 主要用于二孔或四孔的平纽扣缝制。
  2. 若加附具，可缝制带柄及其他纽扣。

### PC1377D Application:

Suitable for shirts, suits, overalls and other double-hole, four-hole or vertical button sewing.

### Features:

1. Three stitches. The stitch “=” and “X” and “+” can be adjusted by simple operation.
2. Change from 4 to 2 holes.
3. Optional installation of electric button feed device.

### PC373 Application:

Attaching two holes or four holes button on shirt, suit or overcoat.

### Features:

- PC373D
1. Mainly use to attach two holes or four holes of straight buttons.
  2. Change the model four holes button to two holes button.
  3. It can add electronic feed button device.
- PC373
1. Mainly use to attach two holes or four holes of straight buttons.
  2. It can sew a handle button and other kind of buttons if add some devices.

|         |  |         |  |       |   |      |   | kg      | mm          |
|---------|--|---------|--|-------|---|------|---|---------|-------------|
| PC1377D | TQx1 16#(14#-18#)<br>TQx7 16#(14#-18#) | 1       |  | 10-28 | 9 | 1500 | ★ | 35/45   | 630×470×440 |
| PC1377  | TQx1 16#(14#-18#)<br>TQx7 16#(14#-18#) | 1       |  | 10-28 | 9 | 1500 | ★ | 35/45   | 630×470×440 |
| PC373D  | TQX714#-18#<br>(标准)                    | 8,16,32 |  | 10-28 | 9 | 1500 | ★ | 26/30.5 | 580×440×430 |
| PC373   | TQX718#-20#<br>(标准)                    | 6,12,24 |  | 10-28 | 9 | 1500 | ★ | 21/25.5 | 505×330×420 |



**PRECIOUS®**

# PC927 臂式双链环缝纫机

High-speed feed-off-the-arm double-chainstitch machine

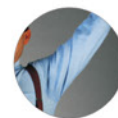

**用途:**  
适用于男装、女装、衬衫、雨披、工作服、牛仔裤、帐篷等缝制。

**特点:**  
悬臂筒型的特殊结构适合袖子、裤筒等形部的搭接缝制。

**Application:**  
Applicable to men's clothing, women's clothing, shirt, rain cape, uniforms, jeans, tents etc.

**Features:**  
Cantilever type of special structure for sleeves, trousers and other parts of the lap joints.

| PC927    | TVX64<br>#11-#16 | 2 | 4 | 1.2-5.2 | 1/4 | 1/8 | 3/16 | 7/32 | 10 | 4000 | 47/65 | 580×545×475 |
|----------|------------------|---|---|---------|-----|-----|------|------|----|------|-------|-------------|
| PC927-PL | TVX64<br>#11-#16 | 2 | 4 | 1.2-5.2 | 1/4 | 1/8 | 3/16 | 7/32 | 10 | 4000 | 47/65 | 580×545×475 |
| PC927-PS | TVX64<br>#11-#16 | 2 | 4 | 1.2-5.2 | 1/4 | 1/8 | 3/16 | 7/32 | 10 | 4000 | 47/65 | 580×545×475 |



# PRECIOUS®

## PC928 臂式双链环缝纫机

### High-speed feed-off-the-arm double-chainstitch machine



PC928XH-2PL



PC928-PS



**用途:**

适用于男装、女装、工作服、休闲裤、牛仔裤、帐篷、牛仔布料的缝制。

**特点:**

悬臂筒型的特殊结构适合袖子、裤筒等形部的搭接缝制。

**Application:**

Applicable to men's clothing, ladies' clothing, shirt, rain cape, uniforms, jeans, tents etc.

**Features:**

Cantilever type of special structure for sleeves, trousers and other parts of the lap joints.

| PC928         | TVX5 #11-#16 | 3 | 6 | 1.2-5.2 | 1/4 | 9/32 | 5/16 | 3/8 | 1/2 | 11 | 4000 | 39/59 |
|---------------|--------------|---|---|---------|-----|------|------|-----|-----|----|------|-------|
| PC928-PL      | TVX5 #18-#21 | 3 | 6 | 1.2-5.2 | 1/4 | 9/32 | 5/16 | 3/8 | 1/2 | 11 | 4000 | 39/59 |
| PC928XH-2PL   | TVX5 #18-#21 | 3 | 6 | 1.2-5.2 | 1/4 | 9/32 | 5/16 | 3/8 | 1/2 | 12 | 4000 | 39/59 |
| PC928-PL/CV   | TVX5 #18-#21 | 3 | 6 | 1.2-5.2 | 1/4 | 9/32 | 5/16 | 3/8 | 1/2 | 12 | 4000 | 39/59 |
| PC928-PS      | TVX5 #18-#21 | 3 | 6 | 1.2-5.2 | 1/4 | 9/32 | 5/16 | 3/8 | 1/2 | 12 | 4000 | 39/59 |
| PC928-PF/CV   | TVX5 #18-#21 | 3 | 6 | 1.2-5.2 | 1/4 | 9/32 | 5/16 | 3/8 | 1/2 | 12 | 4000 | 39/59 |
| PC928HD-PF/CV | TVX5 #18-#21 | 3 | 6 | 1.2-5.2 | 1/4 | 9/32 | 5/16 | 3/8 | 1/2 | 12 | 4000 | 39/59 |





# PRECIOUS®

## PC2290 直驱电子自动剪线曲折缝纫机

## PC2284 高速曲折缝缝纫机

PC2290 Direct drive zigzag sewing machine with auto trimming

PC2284 High-speed Zigzag sewing machine



PC2290



PC2284



镜像缝功能

Mirror inversion switch

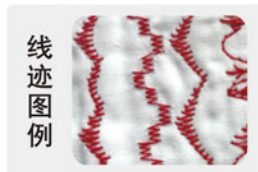

线迹图例



两点四点曲折转换装置  
Two to four points zigzag switching device



### PC2290 用途:

适用于女士内衣、女装夹克、罩衫的领子等。

### 特点:

1. 具有自动剪线、自动倒回缝、自动抬压脚、自动停针等功能。
2. 具有连续缝、循环缝功能。
3. 微油润滑系统，保证缝料清洁。

### PC2284 用途:

适用于女士内衣、夹克、罩衫的领子等针织、内衣的双线锁或人字缝。

### 特点:

1. 实现直缝，2点曲折，4点曲折缝。
2. 通过更换凸轮可进行11种的花样缝。
3. 内置式的绕线器，方便绕线。
4. 采用新型旋转挑线杆，线迹更美观。

### PC2290 Application:

Applicable for lady's underwear, jackets, the collar of the blouse.

### Features:

1. Auto trimming, auto reverse seaming, auto foot lifter, auto needle positioner.
2. With continuous seam, circular seam function.
3. Micro-oil lubrication system to ensure that the sewing material clean.

### PC2284 Application:

Applicable for lady's underwear, jackets, the collar of the blouse and other knitting knitwear, underwear double-line lock or herringbone sewing.

### Features:

1. To achieve straight seam, 2 and 4 points zigzag seam.
2. It can form 11 kinds of pattern stitches by changing the cam.
3. Built-in bobbin winder for easy winding.
4. Adopt new rotary thread take-up, stitch more beautiful.

|  | PC2290 | DPX5            | 1 | ★ | 2 | 5 | 6  | 2000 | 21/25 | 555×250×355 |
|--|--------|-----------------|---|---|---|---|----|------|-------|-------------|
|  | PC2284 | DPX5<br>10#-14# | 1 | ★ | 2 | 5 | 10 | 5000 | 21/25 | 555×250×355 |



# PRECIOUS®

## PC20U..... 曲折缝缝纫机

### Zigzag sewing machine

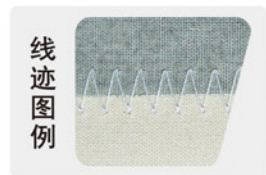

20U23



20U43/53

#### 用途:

适用于服装、鞋帽、皮件、箱包等的薄、中厚料曲折缝、拼缝、装饰缝，线迹美观，操作灵活。

#### 特点:











- 1.采用牙叉送料，旋梭勾线，摆动针杆刺布。
- 2.高程度的机械传动，确保多种线缝的线迹，完美质量。

#### Function:

It is suitable for zigzag, flat seam, abutted seaming on light and medium material, such as garments, shoes and caps, leather articles, bags, etc. Beautiful stitch and easy operation.

#### Features:

1. Fork feeding, hook loop, swing needle bar thorn cloth.
2. High degree of mechanical transmission, to ensure that a variety of seam stitch, perfect quality.

|  |  |  |  |  |  |  |  |  |  |
|---|---|---|---|---|---|---|---|---|---|
|   | DP×5<br>14#   | 0~8   | 35  | 5/12  | 5   | ★   | 1800  | 21/25   | 550×250×365   |
| PC20U23   | DP×5<br>14#   | 0~8   | 35  | 5/12  | 5   | ★   | 1800  | 21/25   | 550×250×365   |
| PC20U33   | DP×5<br>14#   | 0~12  | 35  | 5/12  | 5   | ★   | 2000  | 21/25   | 550×250×365   |
| PC20U43   | DP×5<br>14#   | 0~12  | 35  | 5/12  | 5   | ★   | 1800  | 21/25   | 550×250×365   |
| PC20U53   | DP×5<br>14#   | 0~8   | 35  | 5/12  | 5   | ★   | 2000  | 21/25   | 550×250×365   |
| PC20U63   | DP×5<br>14#   | 0~12  | 35  | 5/12  | 5   | ★   | 1800  | 21/25   | 550×250×365   |
| PC20U93   | DP×5<br>14#   | 0~12  | 35  | 5/12  | 5   | ★   | 1800  | 21/25   | 550×250×365   |



# PRECIOUS®

## PC20058 高速双针链式平缝机

### High-speed double-needle chainstitch sewing machine



PC20058D-4TB



PC20058-1

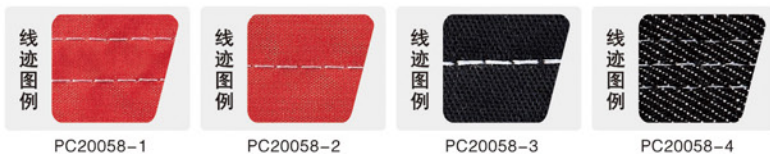

- PC20058
- 1-平行双针链缝  
Horizontal chainstitch
  - 2-单针链缝  
Single chainstitch
  - 3-前后针链缝  
Vertical chainstitch
  - 4-三针链缝  
Three chainstitch
  - D-直驱式单针链缝  
Direct drive chainstitch with needle positional

**用途:**  
适用于服装、内衣、床上用品及薄形包装和皮革制品的搭接缝、装饰缝。

**特点:**  
1. 采用连杆送料机构、针杆挑线、弯针勾线形成链式线迹。  
2. 可选配各种规格的尺寸针位产品。  
3. 可选配加装拖布轮装置，过厚布料更平整、线迹更美观。

**Application:**  
Applicable to lapping decorative seaming underwear, bedding article, light-weight handbag & packages, products.

**Features:**  
1. The chainstitch formed by connecting feed structure, needle bar take-up thread, looper thread hooking.  
2. Needle gauge size optional.  
3. Can add pulley, make the heavy material much smooth and beautiful stitch.

| PC20058D                                | TV×7<br>9-21# | 4 | ★ | 4 | 8-10 | 4500 | —————                               | 35/38 | 610×240×570 |
|---|---------------|---|---|---|------|------|-------------------------------------|-------|-------------|
| PC20058-1<br>(横链)<br>(Horizontal chain) | TV×7<br>9-21# | 4 | ★ | 4 | 8-10 | 4500 | 1/8" 5/32" 7/32"<br>1/4" 5/16" 1/2" | 35/38 | 610×240×570 |
| PC20058-2<br>(单链)<br>(Single chain)     | TV×7<br>9-21# | 2 | ★ | 4 | 8-10 | 4500 | —————                               | 35/38 | 610×240×570 |
| PC20058-3<br>(纵链)<br>(Vertical chain)   | TV×7<br>9-21# | 4 | ★ | 4 | 8-10 | 4500 | 1/8" 5/32" 7/32"<br>1/4" 5/16" 1/2" | 35/38 | 610×240×570 |
| PC20058-4<br>(三链)<br>(Three chain)      | TV×7<br>9-21# | 6 | ★ | 4 | 8-10 | 4500 | —————                               | 35/38 | 610×240×570 |



# PRECIOUS®

## PC2182 珠边机 (贡针机)

### Pinpoint saddle stitch machine(hand-stitch machine)



#### 用途:

专织高档西服、休闲服、牛仔服、衬衣、女裤、羊毛大衣、拉毛大衣各种服装里衫的缝制。

#### 特点:

- 1.采用五针工作原理，解决珠边机上坡、下坡、点针时容易跳针的难题。
- 2.设计先进、性能稳定、效果上佳。
- 3.精心设计的独特供油系统，确保较低的转速也能正常供油，轻轻一按就能有足够的油量供机润滑，延长机器寿命。

#### Application:

Applicable to sew lining pinpoint saddle stitch equipment of top grade suits,Casual wears,jeans,shirts,lady's trousers,wool overcoats,gigging overcoats .

#### Features:

- 1.Adopt five needles working principle to solve the skipped stitch problem when up and down the slope and sewing.
- 2.Advanced design,stable function and good performance.
- 3.Elaborate design for the unique oil supply system, it can provide oil normally even at low speed,using a little oil is enough for operating to prolong the machine's life.

|          |                       |   |   |     |   |      |      | kg      | mm          |
|----------|-----------------------|---|---|-----|---|------|------|---------|-------------|
| PC2182-X | DBX1 14#<br>CPX12 18# | 1 | 2 | 2.1 | 8 | 7/12 | 1800 | 32/33.5 | 570×250×540 |
| PC2182-Z | DPX5 18#<br>CPX12 18# | 1 | 2 | 2.4 | 8 | 7/12 | 1800 | 32/33.5 | 570×250×540 |
| PC2182-C | DPX5 22#<br>CPX12 23# | 1 | 2 | 3   | 8 | 7/12 | 1800 | 32/33.5 | 570×250×540 |
| PC2182-T | DPX5 24#<br>CPX12 25# | 1 | 2 | 4   | 8 | 7/12 | 1800 | 32/33.5 | 570×250×540 |



# PRECIOUS®

## PC388 双针三线花样机

### Double-needle three-thread styling machine

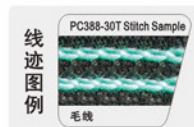
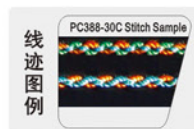

#### 用途:

适用于女装、民族服装、童装、箱包、鞋类、工艺制品等装饰用的缝制。

#### 特点:

1. 自助研发的第三代花样机，在原单针二线的基础上增加一条线，使缝制花色更富于变化。
2. 操作灵活、噪音低、操作空间大、线迹流畅美观。
3. 独特的供油系统，使机器在高速或低速时均能有效均匀的供油润滑各运动部件，提高机器的使用寿命。
4. 缝线色彩及粗细的搭配变化，缝出多种不同效果的线迹。

#### Application:

Applicable to decoration sewing such as ladies and folk costumes, children garments, bags, shoes, crafts etc.

#### Features:

1. Self-researched of the third generation machine, adding one thread basic on single needle two thread, enriched the sewing pattern.
2. Flexible operation, low noise, larger operating space, stitch smooth and beautiful.
3. Unique supply oil system, make the machine to supply oil for all parts effectively whenever at high or low speed and prolong the working life.
4. Colorful thread and thick-thin collocation make kinds of stitches.



PC388-20X

DP×5 16#-18#

左右 一付

1

4

2-6

7/12

1800

32/33.5

570×250×540

PC388-20Z

DP×5 16#-18#

左右 一付

1

4

3-6

7/12

1800

32/33.5

570×250×540

PC388-30C

刀针 (knife needle) 27#

左右 一付

1

4

3-6

7/12

1800

32/33.5

570×250×540

PC388-30T

刀针 (knife needle) 27#

左右 一付

1

4

5-8

7/12

1800

32/33.5

570×250×540



# PRECIOUS®

## PC6699 绳子机(粗线机)

Rope machine (heavy thread machine)

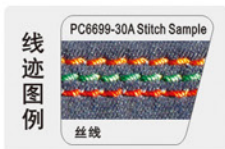

### 用途:

适用于羊毛大衣、拉毛大衣、箱包、皮革、工艺品、民族服装装饰的缝制。

### 特点:

1. 结构独特, 专供装饰线迹。
2. 采用独特旋梭强力送布系统, 最大通过30股绳子丝线及细、中粗毛线。
3. 该刀针、旋梭是我厂独有, 较之目前市场上最粗线旋梭(20股绳子丝线) 有更好更粗的装饰效果。
4. 精心设计的独特供油系统, 确保较低的转速也能正常供油, 轻轻一点就能有足够的油量供机润滑, 延长机器寿命。

### Application:

Applicable to decoration sewing such as woolen coats, giggering overcoats, cases, leathers, crafts, folk costumes etc.

### Features:

1. Special structure, professional for decoration stitch.
2. Adopt unique hook mighty feed system, allowing 30 strands rope of silk thread and thin, moderate thick woolen mostly.
3. Knife needle, hook are exclusively our factory. comparing with the hook for utmost heavy thread (20 strands rope silk thread), they have much better and heavier decoration effect.
4. Elaborate unique oil supply system, ensure supply oil normally when in the low speed, using a little oil is enough for operation to prolong the machine's life.

|            |                       |   |   |   |      |      | kg      | mm          |
|------------|-----------------------|---|---|---|------|------|---------|-------------|
| PC6699-20A | 刀针 (knife needle) 26# | 1 | 2 | 8 | 6/13 | 2000 | 32/33.5 | 570×250×540 |
| PC6699-20B | 刀针 (knife needle) 26# | 1 | 2 | 8 | 6/13 | 2000 | 32/33.5 | 570×250×540 |
| PC6699-30A | 刀针 (knife needle) 28# | 1 | 2 | 8 | 6/13 | 2000 | 32/33.5 | 570×250×540 |
| PC6699-30B | 刀针 (knife needle) 28# | 1 | 2 | 9 | 6/13 | 2000 | 32/33.5 | 570×250×540 |



**PRECIOUS®**

# PC6200D-01-MR-AT/AW 直驱曲臂式四针六线拼缝机

Direct drive 4-needle 6-thread feed-off-the-arm flat seamer



- 1. 01.切布装置  
Fabric cutter system  
基本款单切布装置  
Basic type(single cut)
- 12双切布装置  
Double cut
- 03.单切布贴条装置  
Single cut and attaching  
line tape system
- 2.适用面料厚度 Fabric thickness  
M=薄料~中厚料  
M=light~medium weight fabric  
H=厚料 H=Heavy weight fabric
- 3.针距 Gauge size  
R=5.2mm  
S=6.0mm
- 4.抬压脚装置 Foot lift system  
AT:气动抬压脚  
AT:foot lift by air  
ET:电动抬压脚  
ET:foot lift by electricity
- 5.附属装置 Attachment  
AW:气动吸布屑装置  
AW:automatic air wiper system  
EW:电动吸布装置  
EW:automatic wiper system  
by electricity

线迹图例



线迹图例



**用途:**  
适用于伸缩布料如T恤衫、内裤、潜水衣、保腰裤的拼缝缝制。

**Application:**  
Applicable for stretch fabric flat seam such as T-shirt, underwear, wet suit, and waist trousers.



PC6200D-01-MR-AT/AW



FLX118GCSX4#9



R=5.2mm  
S=6.0mm



4



6



1.6-2.5



8



4200



# PRECIOUS®

## PC910/PC920 高台车

Post bed machine



### 用途:

适用于各类旅游鞋、运动鞋、女鞋、马靴及手袋的缝制。

### 特点:









- 1.采用新式方形壳体设计，线条流畅、造型美观大方。
- 2.新型设计增加了整机稳固性、减少了运动震动对缝纫的影响，操作更舒适、缝制更稳定、线迹更美观。
- 3.翻转式、旋梭护盖、维修更加方便、外观设计更加新颖美观、表面电镀增加了表面耐磨性。

### Application:

Applicable to all kinds of tourist shoes, gym shoes, ladies' shoes, riding boots and handbag sewing.

### Features:

- 1.Adopt the new square shell design, nice appearance.
- 2.The new design increases the stability of the machine, reduces the impact of vibration on sewing, and makes the operation more comfortable, the sewing more stable and the stitch more beautiful.
- 3.Flip type and hook cover, make maintenance more convenient, appearance design more novel and beautiful, surface electroplating added surface wear resistance.

|  |  |  |  |  |  | <br>kg | <br>mm |
|---|---|---|---|---|--|---|---|
| PC910   | DPX5<br>14#-21#   | 2   | 5   | 6/13  | 2000   | 39/43   | 670×250×560   |
| PC920   | DPX5<br>14#-21#   | 4   | 5   | 6/13  | 2000   | 39/43   | 670×250×560   |





# PRECIOUS®

## PC9910D/PC9920D 直驱罗拉车

Direct drive roller machine



PC9910D



PC9920D

**用途:**

适用于马靴、运动鞋、工作鞋、休闲鞋、海绵鞋、婴儿鞋、高级皮革鞋类及箱包缝制。

**特点:**









- 1. 采用双滚针及同步送料，爬坡力强，针距变化小，针位极稳固。
- 2. 缝制海绵、薄皮等缝料，平滑均匀，不起皱，不变形。
- 3. 采用球型及针状轴承，润滑性能好、摩擦小、噪音低，经久耐用。

**Application:**

Applicable to riding boots, gym shoes, working shoes, leisure shoes, sponge shoes, baby shoes, top grade leather shoes and bags sewing.

**Features:**

- 1. Adopt to double idler wheel and synchronous feeding, with strong climbing force, small change of needle and stable needle position.
- 2. Sewing sponges, thin leather and other sewing materials, smooth and uniform, not wrinkled, not deformed.
- 3. Using ball type and needle bearings, good lubrication, small friction, low noise and durable.

|  |  |  |  |  |  |  |  |
|---|---|---|---|---|--|---|---|
|   |   |   |   |   |  | kg  | mm  |
| PC9910D   | DPX5<br>14#-21#   | 2   | 7   | 7/13  | 2500   | 51/56   | 670×340×680   |
| PC9920D   | DPX5<br>14#-21#   | 4   | 5.5   | 7/13  | 2500   | 51/56   | 670×340×680   |



**PRECIOUS®**

# PC450/PC600 拉帮机

Upper drawing machine



PC450



PC600

**用途:**

适用于水貂皮、狐皮、黄狼皮、兔皮、狗皮等厚料裘皮的缝制。

**特点:**







- 1.采用箱式主体、针杆挑线、勾针勾线、齿盘送料。
- 2.具有自由润滑装置，是皮毛拼缝缝纫理想设备。

**Application:**

Applicable to mink fur, fox fur, weasel fur, rabbit fur and dog fur and other heavy fur sewing .

**Features:**

- 1.Adopt box-type frame, needle bar take-up thread, loop thread, teeth feeding.
- 2.With auto-lubrication device, it is the ideal equipment for flat seam.

|  |  |  |  |  |  |
|---|---|---|---|---|---|
|   |   |   |   | kg  | mm  |
| PC450   | CPX5<br>19#-23#   | 6   | 3000  | 30/34.5   | 430×330×535   |
| PC600   | DPX5<br>19#-23#   | 8   | 3000  | 28/30   | 495×405×375   |



**PRECIOUS®**

# PC818 大白扣机

Snap button machine



**用途:**

适用性强, 可在各种面料及皮革等制品上安装各种纽扣、铆钉等。

**特点:**

1. 装有保险安全装置, 不会误伤手的现象。
2. 无极调整钉扣所需的压力。
3. 气压式系统自动润滑、寿命长使用维修方便。
4. 可选配各种专用模具。

**Application:**

Wide applicability, can be used in various fabrics and leather products to install various buttons, rivet, etc.

**Features:**

1. With insurance safety device, will not accidental injury hands.
2. Non-polar adjust the presser of button.
3. Pneumatic system automatic lubrication, prolong made life and convenient maintenance.
4. Can selected many kinds of special moulds.



PC818



34mm



2500



kg

25/30



mm

670×340×680



# PRECIOUS®

## PC500/600 暗缝机 PC861 工业用裤耳暗缝机

PC500/600 Table blindstitch machine  
PC861 Industrial trousers ears blindstitch machine



PC861



7mm-10mm



11mm-15mm



PC500



PC600

PC500 Stitch Sample

线迹图例



PC600 Stitch Sample

线迹图例



### PC600用途:

可直接利用边角余料; 西裤裤耳暗缝专用。

### 特点:

1. 带下切刀装置。
2. 带前送布装置。
3. 专用于暗缝环形裤子耳等。
4. 订购时请简单说明缝制品的宽度和缝料的厚度宽度和厚度成品幅宽: 8、9、10、11mm。

### PC500用途:

适用于裙摆、裤管、袖口、袋口、领襟、裤头、纺织物的链缝, 盲缝。

### 特点:

内置隐藏式马达, 具有体积小, 坚固耐用, 安全省电, 操作简单, 功能齐全等。

### PC600 Application:

Direct use of edge angle material, Specially for the suit pants belt loop.

### Features:

1. With button cutter device.
2. With front feeding device.
3. Specially for blind seam ring pant belt loop.
4. Please indicate the width and thickness of the product, width and thickness of the product range: 8, 9, 10, 11mm.

### PC500 Application:

Applicable for hemline, trousers, cuff, sleeves pockets, neckbands, trousers, textiles fabric and other blind seam.

### Features:

Built-in motor, little volume, strong and durable, safety power, simple operation, complete functions, etc.



PC500

GC×1型NM65-100  
LW×6T  
11" - 14"

1:1

1:2

5

★

7

1200

100

11/14

400×360×330

PC600

GC×1型NM65-100  
LW×6T  
11" - 14"

1:1

1:2

6

★

10

2000

250

23/28

475×430×375

PC861

LW×6T

1:1

2:1

6

3-8

9

1800

250

23/28

475×430×375



# PRECIOUS®

## PC26-1 手提封包机

Portable bag closer



**用途:**

适用于装满水泥、糖、面粉、化肥、粮食、塑料等口袋、纸袋、编织袋的封口。

**特点:**









PC26-1 采用单线链式线迹的专用手提式封包机。  
PC26-1A 增加手掀油泵润滑的单线链式线迹。  
PC26-2A 采用双针双线链式线迹。

**Application:**

Suitable for sealing the pocket, paper bag and woven bag which filled cement, sugar, flour, fertilizer, cereals, plastic etc.

**Features:**

PC26-1 Special portable sealing machine with single thread chain stitch.  
PC26-1A Increases the single thread chainstitch of the lubrication of hand lift oil pump.  
PC26-2A Adopt double - needle and thread chainstitch.

|  |  |  | <br>mm |  |  |  | <br>kg | <br>mm |
|---|---|---|---|---|---|---|---|---|
| PC26-1  | DN×1<br>25#   | 1   | 6.5   | 6   | 1250  | 220/110   | 5.6/8   | 400×270×360   |
| PC26-1A   | DN×1<br>25#   | 1   | 6.5   | 6   | 1250  | 220/110   | 5.6/8   | 400×270×360   |
| PC26-2A   | DN×1<br>25#   | 2   | 6.5   | 6   | 1250  | 220/110   | 5.6/8   | 400×270×360   |



# PRECIOUS®

## PC-T3/PC103 自动磨刀裁剪

### PC-T3/PC103 Auto-sharpening cutting machine



PC-T3



PC103

**用途:**

适用于剪裁棉、毛、麻、丝绸、化纤、海绵、皮革等面料。

**特点:**





- 1.该机的零部件可以与日本KS-AUS互换。
- 2.采用大功率电动机，离心开关启动。
- 3.装有自动磨刀装置和自动润滑系统。具有工作平稳，操作灵便和剪裁能力强等特点。

**Application:**

Applicable to cutting cotton, woolen, linen, silk, chemical fiber, sponge, leather and other material.

**Features:**

- 1.The parts of this machine can be exchanged with Japanese KS-AUS.
- 2.Adopt powerful motor, centrifugal switch starting.
- 3.Equipped with automatic knife grinding device and lubrication system.It has features of stable running, convenient operation and powerful cutting convenient operation and powerful cutting ability etc.

|  |  | 电压<br>Voltage<br>v | 频率<br>Frequency<br>HZ | 最大剪裁高度<br>Cutting Height<br>mm             |  | <br>kg | <br>mm |
|---|---|--------------------|-----------------------|--|---|---|---|
| PC-T3   | 550-750   | 220/110            | 50/60                 | 110、160、<br>210、260                        | 2800/3400   | 15/18   | 760×405×300   |
| PC103   | 550-750   | 220/110            | 50/60                 | 194(6")<br>244(8")<br>294(10")<br>344(12") | 2800/3400   | 15/18   | 760×405×320   |

## 汇宝电脑绣花机

PRECIOUS INDUSTRIAL COMPUTER EMBROIDERY MACHINE

## 全伺服高速机

Full servo high speed machine

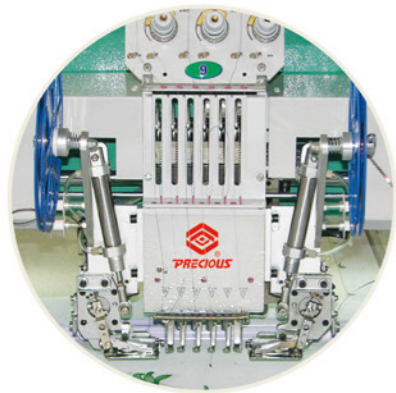

### 功能特点 Functions and Features

速度最快达到1200转/分

主电机采用整套伺服电控系统，x、y方向也采用伺服电机控制，主轴的运转及绣框的运作精确、平稳。

自动加油装置保证定时定量给重要机械结构部位自动加油润滑。

新款框架驱动系统提供了强劲的动力，保证了框架运作的精确性和平稳性。

针杆架内部机械结构设计精确，保证了针杆凸轮、挑线凸轮的牢固性和稳定性。

Max speed can be up to 1200rpm.

Machine adopts full servo control system for X/Y and main-shaft and frame running precisely and stably

Automatic lubrication system guarantees timely and rationed lubrication at important mechanisms.

New frame deiving system provides stronger power to enable the border frame to move stably and accurately.

Inside mechanism structure of the needle bar case is designed precisely, which guarantees the fastness and stability of needle bar cam and take up lever cam.

注：本公司可根据用户不同需求，定制各种不同规格的绣花机。  
According to customer's different requirements we can make embroidery machines with different specifications.